

OCF Device Specification

VERSION 2.2.0 | July 2020



OPEN CONNECTIVITY
FOUNDATION™

CONTACT admin@openconnectivity.org

Copyright Open Connectivity Foundation, Inc. © 2020.
All Rights Reserved.

Legal Disclaimer

3
4
5
6
7
8
9
10
11
12
13
14
15
16
17
18
19
20

NOTHING CONTAINED IN THIS DOCUMENT SHALL BE DEEMED AS GRANTING YOU ANY KIND OF LICENSE IN ITS CONTENT, EITHER EXPRESSLY OR IMPLIEDLY, OR TO ANY INTELLECTUAL PROPERTY OWNED OR CONTROLLED BY ANY OF THE AUTHORS OR DEVELOPERS OF THIS DOCUMENT. THE INFORMATION CONTAINED HEREIN IS PROVIDED ON AN "AS IS" BASIS, AND TO THE MAXIMUM EXTENT PERMITTED BY APPLICABLE LAW, THE AUTHORS AND DEVELOPERS OF THIS SPECIFICATION HEREBY DISCLAIM ALL OTHER WARRANTIES AND CONDITIONS, EITHER EXPRESS OR IMPLIED, STATUTORY OR AT COMMON LAW, INCLUDING, BUT NOT LIMITED TO, IMPLIED WARRANTIES OF MERCHANTABILITY OR FITNESS FOR A PARTICULAR PURPOSE. OPEN CONNECTIVITY FOUNDATION, INC. FURTHER DISCLAIMS ANY AND ALL WARRANTIES OF NON-INFRINGEMENT, ACCURACY OR LACK OF VIRUSES.

The OCF logo is a trademark of Open Connectivity Foundation, Inc. in the United States or other countries. *Other names and brands may be claimed as the property of others.

Copyright © 2016-2020 Open Connectivity Foundation, Inc. All rights reserved.

Copying or other form of reproduction and/or distribution of these works are strictly prohibited.

CONTENTS

21
22
23
24
25
26
27
28
29
30
31
32
33
34
35
36
37
38
39
40
41
42
43
44
45
46
47
48
49
50
51
52
53
54
55
56
57
58
59
60
61
62
63

1	Scope	1
2	Normative references	1
3	Terms, definitions, and abbreviated terms	1
3.1	Terms and definitions	1
3.2	Abbreviated terms	2
4	Document conventions and organization	3
4.1	Conventions	3
4.2	Notation	3
4.3	Data types	4
4.4	Document structure	4
5	Operational scenarios	5
5.1	Document version	5
6	Core resource model	5
6.1	Introduction	5
6.2	Device type	5
6.3	Profile of ISO/IEC 30118-1:2018	6
6.4	Third (3 rd) party specified extensions	6
6.5	Semantic Tags	7
6.5.1	Introduction	7
6.5.2	"tag-pos-desc" or position description Semantic Tag	7
6.5.3	"tag-func-desc" or function description Semantic Tag	8
7	Modelling of multiple logical devices	8
7.1	Introduction	8
7.2	Single platform model	8
7.3	Multi-platform model	8
7.4	Composite device model	8
8	Discovery	10
8.1	Endpoint discovery	10
8.2	Resource discovery	10
9	Security	11
Annex A (normative)	Device categories and device types	12
A.1	Device categories	12
A.2	Device types	12
Annex B (normative)	Smart home device types	18
B.1	Smart home required resources per device type	18
B.2	Standardized enumeration values	21
B.2.1	Introduction	21
B.2.2	Alphabetical list of standardized enumeration types	21
B.2.3	Standardized list of supported values for mode resource type (oic.r.mode)	27
B.2.4	Standardized list of supported values for operational state resource type (oic.r.operational.state)	30

64	B.2.5	Standardized list of supported values for consumable and consumable collection resource types (oic.r.consumable, oic.r.consumablecollection)	36
65			
66	B.3	Camera media format (oic.r.media)	37
67	B.4	Additional requirements per device type.....	38
68	B.4.1	Additional requirements for Television Devices ("oic.d.tv").....	38
69	Annex C (normative)	Healthcare device types	39
70	C.1	Scope	39
71	C.2	Introduction to OCF healthcare devices	39
72	C.3	Operational scenarios	39
73	C.4	Standardized device types	40
74	C.4.1	Introduction	40
75	C.4.2	Blood pressure monitor.....	41
76	C.4.3	Glucose meter	42
77	C.4.4	Body scale.....	43
78	C.4.5	Body thermometer	44
79	C.4.6	Heart rate monitor	45
80	C.4.7	Pulse oximeter.....	45
81	C.4.8	Sleep monitor	46
82	C.4.9	Activity tracker.....	47
83	C.4.10	CGM (Continuous Glucose Meter)	48
84	C.4.11	Cycling power meter	49
85	C.4.12	Cycling speed sensor	49
86	C.4.13	Cycling cadence sensor.....	50
87	C.4.14	Muscle oxygen monitor.....	50
88	C.4.15	Body composition analyser	51
89	Annex D (normative)	Industrial device types	53
90	D.1	Operational scenarios	53
91	D.2	Industrial required resources per device type	56
92	Annex E (normative)	PV (Photovoltaic) system device types	57
93	E.1	Scope	57
94	E.2	Operational scenarios	57
95	E.3	Standard device types	59
96			

Figures

97	
98	Figure 1 – Device building blocks.....5
99	Figure 2 – Example composite device model9
100	Figure 3 – RETRIEVE response to example door from composite device model..... 10
101	Figure B.1 – Example of mode transitions of a dryer 30
102	Figure B.2 – Example of job state transitions of a printer36
103	Figure C.1 – Schematic diagram of healthcare usages.....40
104	Figure D.1 – Normal process scheme of optical augmented RFID in smart factory
105	environment..... 54
106	Figure D.2 – Abnormal process scheme of optical augmented RFID in smart factory
107	environment..... 55
108	Figure E.1 – Classification of electrical grid facility57
109	Figure E.2 – Typical PV system configuration 58
110	Figure E.3 – Detailed configuration of PV array system..... 59
111	

Tables

112		
113	Table 1 – Required resources for devices	6
114	Table 2 – Required properties in resource	6
115	Table 3 – 3rd party defined Resource elements	7
116	Table A.1 – List of device categories	12
117	Table A.2 – Per category list of device types	12
118	Table B.1 – Alphabetical list of device types ("rt"), including required resources for smart	
119	home	18
120	Table B.2 – The defined set of standardized enumerations	21
121	Table B.3 – List of supported "oic.r.mode" values per Device Type ("rt")	27
122	Table B.4 – List of supported "oic.r.operational.state" values per Device Type ("rt")	30
123	Table B.5 – List of supported values per Device Type ("rt") for jobStates of operational	
124	state resource type	31
125	Table B.6 – List of defined enumeration values for oic.r.consumable,	
126	oic.r.consumablecollection	37
127	Table B.7 – Recommended media profiles	37
128	Table C.1 – Alphabetical list of healthcare device types	40
129	Table C.2 – Commonly used resource types of healthcare device types	41
130	Table C.3 – Healthcare device type of blood pressure monitor	42
131	Table C.4 – Atomic measurement of blood pressure monitor	42
132	Table C.5 – Healthcare device type of glucose meter	42
133	Table C.6 – Atomic measurement of glucose meter	42
134	Table C.7 – Healthcare device type of body scale	43
135	Table C.8 – Atomic measurement type of body scale	43
136	Table C.9 – Healthcare device type of body thermometer	44
137	Table C.10 – Atomic measurement type of body thermometer	44
138	Table C.11 – Healthcare device type of heart rate monitor	45
139	Table C.12 – Atomic measurement of heart rate monitor	45
140	Table C.13 – Healthcare device type of pulse oximeter	45
141	Table C.14 – Atomic measurement of pulse oximeter	46
142	Table C.15 – Healthcare device type of sleep monitor	46
143	Table C.16 – Atomic measurement of sleep monitor	47
144	Table C.17 – Healthcare device type of activity tracker	47
145	Table C.18 – Atomic measurement of activity tracker	47
146	Table C.19 – Healthcare device type of CGM	48
147	Table C.20 – Atomic measurement of CGM	48
148	Table C.21 – Healthcare device type of cycling power meter	49
149	Table C.22 – Healthcare device type of cycling speed sensor	50
150	Table C.23 – Healthcare device type of cycling cadence sensor	50
151	Table C.24 – Healthcare Device Type of muscle oxygen monitor	50
152	Table C.25 – Healthcare device type of body composition analyser	51

153	Table C.26 – Atomic measurement type of body composition analyser.....	51
154	Table D.1 – Alphabetical list of device types ("rt"), including required resources for	
155	Industrial.....	56
156	Table E.1 – Function and required resources for PV system device types.....	59
157	Table E.2 – List of PV system device types.....	59
158		

159 **1 Scope**

160 ISO/IEC 30118-5 is an Application Profile specification.

161 The Device definitions use Resource definitions from the ISO/IEC 30118-4:2018.

162 This document is built on top of ISO/IEC 30118-1:2018. ISO/IEC 30118-1:2018 specifies the core
163 architecture, interfaces protocols and services to enable the implementation of profiles for IoT
164 usages and ecosystems. ISO/IEC 30118-1:2018 also defines the main architectural components of
165 network connectivity, discovery, data transmission, device & service management and ID & security.
166 The core architecture is scalable to support simple devices (constrained devices) and more capable
167 devices (smart devices).

168 **2 Normative references**

169 The following documents are referred to in the text in such a way that some or all of their content
170 constitutes requirements of this document. For dated references, only the edition cited applies. For
171 undated references, the latest edition of the referenced document (including any amendments)
172 applies.

173 ISO/IEC 30118-1:2018 Information technology -- Open Connectivity Foundation (OCF)
174 Specification -- Part 1: Core specification
175 <https://www.iso.org/standard/53238.html>
176 Latest version available at: https://openconnectivity.org/specs/OCF_Core_Specification.pdf

177 ISO/IEC 30118-2:2018 Information technology -- Open Connectivity Foundation (OCF)
178 Specification -- Part 2: Security specification
179 <https://www.iso.org/standard/74239.html>
180 Latest version available at: https://openconnectivity.org/specs/OCF_Security_Specification.pdf

181 ISO/IEC 30118-4:2018 Information technology -- Open Connectivity Foundation (OCF)
182 Specification -- Part 4: Resource type specification
183 <https://www.iso.org/standard/74241.html>
184 Latest version available at:
185 https://openconnectivity.org/specs/OCF_Resource_Type_Specification.pdf

186 ISO/IEC 61850-7-1:2011 Communication networks and systems for power utility automation --Part
187 7-1: Basic communication structure -- Principles and models
188 <https://webstore.iec.ch/publication/6014>

189 OpenAPI specification, fka *Swagger RESTful API Documentation Specification*, Version 2.0
190 <https://github.com/OAI/OpenAPI-Specification/blob/master/versions/2.0.md>

191 IETF RFC 4566, SDP: Session Description Protocol, July 2006
192 <https://tools.ietf.org/html/rfc4566>

193 Draft Report: A Basic Classification System for Energy-Using Products--Universal Device
194 Classification, December 2013
195 <https://eta-intranet.lbl.gov/sites/default/files/lbnl-classification-v1.pdf>

196 **3 Terms, definitions, and abbreviated terms**

197 **3.1 Terms and definitions**

198 For the purposes of this document, the terms and definitions given in ISO/IEC 30118-1:2018 and
199 ISO/IEC 30118-2:2018 and the following apply.

200 ISO and IEC maintain terminological databases for use in standardization at the following
201 addresses:

202 – ISO Online browsing platform: available at <https://www.iso.org/obp>

203 – IEC Electropedia: available at <http://www.electropedia.org/>

204 **3.1.1**

205 **Actuator**

206 resource with support of the UPDATE operation.

207 **3.1.2**

208 **Sensor**

209 resource without support of the UPDATE operation.

210 **3.1.3**

211 **Healthcare Device**

212 a Device that is conformant to the normative requirements contained in Annex C of this document.

213 **3.2 Abbreviated terms**

214 **3.2.1**

215 **CGM**

216 Continuous Glucose Monitor

217 Device that continuously measures patient's glucose information throughout the day and night, and
218 notifies highs and lows for control of patient blood sugar levels.

219 **3.2.2**

220 **CRUDN**

221 Create Retrieve Update Delete Notify

222 This is an acronym indicating which operations are possible on the Resource.

223 **3.2.3**

224 **CSV**

225 Comma Separated Value

226 Comma Separated Value is a construction to have more fields in 1 string separated by commas. If
227 a value itself contains a comma, then the comma can be escaped by adding "\" in front of the
228 comma.

229 **3.2.4**

230 **NREM**

231 Non Rapid Eye Movement

232 Type of sleep including 3 to 4 stages of the sleep cycle defining Light Sleep and Deep Sleep, which
233 are cycled through before the REM type of sleep.

234 **3.2.5**

235 **REM**

236 Rapid Eye Movement

237 Type of sleep where the eyes are moving rapidly from side to side beneath the closed eyelids.

238 **3.2.6**

239 **Representational State Transfer**

240 **REST**

241 REST is an architecture style for designing networked applications that relies on a stateless, client-
242 server, cacheable communications protocol.

243 **3.2.7**

244 **SDP**

245 Session Description Protocol

246 SDP describes multimedia sessions for the purposes of session announcement, session invitation,
247 and other forms of multimedia session initiation. It is fully defined in IETF RFC 4566.

248 **3.2.8**
249 **UDC**
250 Universal Device Classification
251 An enumeration of device types published as A Basic Classification System for Energy-Using
252 Products--Universal Device Classification

253 **4 Document conventions and organization**

254 **4.1 Conventions**

255 In this document a number of terms, conditions, mechanisms, sequences, parameters, events,
256 states, or similar terms are printed with the first letter of each word in uppercase and the rest
257 lowercase (e.g., Network Architecture). Any lowercase uses of these words have the normal
258 technical English meaning.

259 **4.2 Notation**

260 In this document, features are described as required, recommended, allowed or DEPRECATED as
261 follows:

262 Required (or shall or mandatory).

263 These basic features shall be implemented. The phrases "shall not", and "PROHIBITED"
264 indicate behaviour that is prohibited, i.e. that if performed means the implementation is not in
265 compliance.

266 Recommended (or should).

267 These features add functionality supported by a Device and should be implemented.
268 Recommended features take advantage of the capabilities a Device, usually without imposing
269 major increase of complexity. Notice that for compliance testing, if a recommended feature is
270 implemented, it shall meet the specified requirements to be in compliance with these guidelines.
271 Some recommended features could become requirements in the future. The phrase "should
272 not" indicates behaviour that is permitted but not recommended.

273 Allowed (or allowed).

274 These features are neither required nor recommended by a Device, but if the feature is
275 implemented, it shall meet the specified requirements to be in compliance with these guidelines.

276 Conditionally allowed (CA).

277 The definition or behaviour depends on a condition. If the specified condition is met, then the
278 definition or behaviour is allowed, otherwise it is not allowed.

279 Conditionally required (CR).

280 The definition or behaviour depends on a condition. If the specified condition is met, then the
281 definition or behaviour is required. Otherwise the definition or behaviour is allowed as default
282 unless specifically defined as not allowed.

283 DEPRECATED

284 Although these features are still described in this document, they should not be implemented
285 except for backward compatibility. The occurrence of a deprecated feature during operation of
286 an implementation compliant with the current document has no effect on the implementation's
287 operation and does not produce any error conditions. Backward compatibility may require that
288 a feature is implemented and functions as specified but it shall never be used by
289 implementations compliant with this document.

290 Strings that are to be taken literally are enclosed in "double quotes".

291 Words that are emphasized are printed in *italic*.

292 **4.3 Data types**

293 See ISO/IEC 30118-1:2018.

294 **4.4 Document structure**

295 This document describes specific requirements governing the indication of Device Types on
296 Devices and the requirements that are associated with specific Device Types themselves. The
297 document makes use of functionality defined in the ISO/IEC 30118-1:2018 and ISO/IEC 30118-
298 4:2018.

299 Annex A specifies the Device Types that shall be used by an OCF Device.

300 Annex B specifies the profiles that that shall be used by an OCF Device that is part of the Smart
301 Home vertical.

302 Annex C specifies the profiles that shall be used by an OCF Device that is part of the Healthcare
303 vertical.

304 Annex D specifies the profiles that shall be used by an OCF Device that is part of the Industrial
305 vertical.

306 This document further describes which constructs are used for a Device and which Resources are
307 mandated to be implemented for each Device. A typical Device consisting of data elements defined
308 in the referenced documents is depicted in Figure 1.

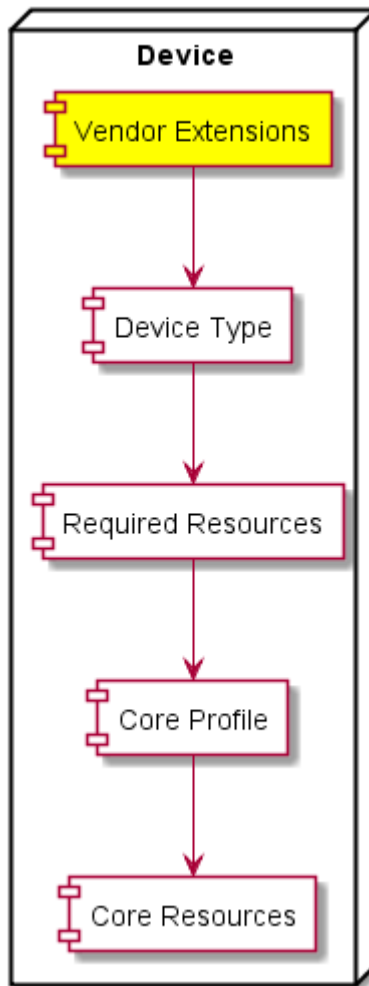

Figure 1 – Device building blocks

309

310

311 5 Operational scenarios

312 5.1 Document version

313 All Devices conformant to this document shall add the string "ocf.sh.1.3.0" to the dmV Property in
 314 oic.wk.d. This Property is for legacy Device support only and will no longer be revised in alignment
 315 with document versions.

316 6 Core resource model

317 6.1 Introduction

318 The Core Resource model is described in ISO/IEC 30118-1:2018.

319 6.2 Device type

320 The Device Types of all devices shall have a Resource Type name ("rt") prefixed with "oic.d."

321 Examples of Device Types are:

- 322 – oic.d.fan
- 323 – oic.d.thermostat

324 The full list of defined Device names and types are in Table A.2, Annex B, Annex C, Annex D, and
 325 Annex E detail the minimal Resource(s) that a Device shall implement for a specific Device Type
 326 where required by a vertical. A Device may expose additional OCF and 3rd party defined Resources
 327 other than those indicated in these Annexes.

328 ISO/IEC 30118-1:2018 defines a Device Resource with a URI of "/oic/d". A Device shall include in
 329 the "Resource type" Property of "/oic/d" the Device Type (or Device Types) from Table A.2 of the
 330 physical device hosting the Server; the inclusion of the Device Type shall be done using one of the
 331 methods provided by clause 11.3.4 of ISO/IEC 30118-1:2018 (i.e. add to the array of values).

332 ISO/IEC 30118-1:2018 supports the inclusion of a Device Type as part of the Resource Type of a
 333 Collection (see also clause 7.4), in such cases the Collection shall include the Resource Types
 334 defined as mandatory for the Device Type by this document. For example, if a Collection Resource
 335 has an "rt" value of ["oic.d.light"], the Collection includes an instance of "oic.r.switch.binary" which
 336 is mandatory for an "oic.d.light" as per clause B.1.

337 Therefore a Device may be discovered by adding a query for the "rt" of the Device Type itself (e.g.
 338 "?rt=oic.d.fan") to the multicast Endpoint discovery method (see 8.1).

339 6.3 Profile of ISO/IEC 30118-1:2018

340 This clause describes the profiling of the Core Resources and transport mechanisms and functions
 341 that are defined in ISO/IEC 30118-1:2018.

342 The required ISO/IEC 30118-1:2018 Resources are also required for a profile implementation.

343 In addition to the required Resources the optional ISO/IEC 30118-1:2018 Resources in Table 1
 344 shall be required.

345 **Table 1 – Required resources for devices**

Resource ("rt")	Required in Profile
Intentionally left blank	Intentionally left blank

346 For each of the Resources listed in Table 1, Table 2 details the Properties within those Resources
 347 that shall be required.

348 **Table 2 – Required properties in resource**

Resource ("rt")	Property name	Required in Profile
Intentionally left blank	Intentionally left blank	Intentionally left blank

349 A Device shall support CoAP based endpoint discovery as defined in clause 10.3 of ISO/IEC 30118-
 350 1:2018.

351 The messaging protocol for a Device shall be CoAP (see ISO/IEC 30118-1:2018).

352 A Device shall support a network layer as defined in clause 9 of ISO/IEC 30118-1:2018 including
 353 any necessary defined bridging functions that ensure inter-operability with IPv6.

354 6.4 Third (3rd) party specified extensions

355 This clause describes how a 3rd party may add Device Types, Resource Types, 3rd party defined
 356 Properties to an existing or 3rd party defined Resource Type, 3rd party defined enumeration values
 357 to an existing enumeration and 3rd party defined Parameters to an existing defined Property.

358 A 3rd party may specify additional (non-OCF) Resources within an OCF Device. A 3rd party may
 359 also specify additional Properties within an existing OCF defined Resource Type. Further a 3rd
 360 party may extend an OCF defined enumeration with 3rd party defined values.

361 A 3rd party defined Device Type may expose both 3rd party and OCF defined Resource Types. A
 362 3rd party defined Device Type must expose the mandatory Resources for all OCF Devices defined
 363 within this document.

364 A 3rd party defined Resource Type shall include any mandatory Properties defined in this document
 365 and also any vertical specified mandatory Properties. All Properties defined within a 3rd party
 366 defined Resource Type that are part of the OCF namespace that are not Common Properties as
 367 defined in this document shall follow the 3rd party defined Property rules in Table 3.

368 Table 3 defines the syntax rules for 3rd party defined Resource Type elements. Within the table the
 369 term "Domain_Name" refers to a domain name that is owned by the 3rd party that is defining the
 370 new element.

371 **Table 3 – 3rd party defined Resource elements**

	Resource Element	Vendor Definition Rules
New 3 rd party defined Device Type	"rt" Property Value of "/oic/d"	"x.<Domain_Name>.<Resource identification>"
New 3 rd party defined Resource Type	"rt" Property Value	"x.<Domain_Name>.<Resource identification>"
New 3 rd party defined Property within the OCF namespace	Property Name	"x.<Domain_Name>.<Property>"
Additional 3 rd party defined values in an OCF specified enumeration	Enumeration Property Value	"x.<Domain_Name>.<enum value>"
Additional 3 rd party defined Parameter in an OCF specified Property	Parameter key word	x.<Domain_Name>.<parameter keyword>

372
 373 With respect to the use of the Domain_Name in this scheme the labels are reversed from how they
 374 appear in DNS or other resolution mechanisms. The 3rd party defined Device Type and Resource
 375 Type otherwise follow the rules defined in ISO/IEC 30118-1:2018. 3rd party defined Resource Types
 376 should be registered in the IANA Constrained RESTful Environments (CoRE) Parameters registry.

377 For example:

378 x.com.samsung.galaxyphone.accelerator
 379 x.com.cisco.ciscorouterport
 380 x.com.hp.printerhead
 381 x.org.allseen.newinterface.newproperty

382 **6.5 Semantic Tags**

383 **6.5.1 Introduction**

384 Semantic Tags are meta-information associated with a specific Resource instance that are
 385 represented as both Link Parameters and Resource Properties that provide a mechanism whereby
 386 the Resource be annotated with additional contextual metadata that helps describe the Resource.
 387 The requirements are defined in ISO/IEC 30118-1:2018, but clauses 6.5.2 and 6.5.3 define
 388 additional Device specific requirements.

389 **6.5.2 "tag-pos-desc" or position description Semantic Tag**

390 In addition to the requirements defined in ISO/IEC 30118-1:2018 the following requirements will
 391 apply:

- 392 – This Semantic Tag should not contain any 3rd party defined values (see clause 6.4).

393
 394
 395

396 **6.5.3 "tag-func-desc" or function description Semantic Tag**

397 In addition to the requirements defined in ISO/IEC 30118-1:2018 the following requirements will
398 apply:

- 399 – This Semantic Tag when exposed shall be populated with a value from the currently supported
400 set of standardized enumeration values defined in clause B.2.2.
- 401 – This Semantic Tag should not contain any 3rd party defined values (see clause 6.4).

402 **7 Modelling of multiple logical devices**

403 **7.1 Introduction**

404 A physical Device may be modelled as a single Platform and Device, a single Platform with multiple
405 Devices, multiple separately discoverable discrete Platforms and Devices, or as a single Platform
406 and Device where the Device is represented as a composition of other Devices.

407 For example, a door that includes the functionality of a contact sensor, a lock and a camera may
408 be modeled as a single-Platform, a multi-Platform, or a Composite Device. Each of these three
409 options will be detailed in clauses 7.2, 7.3, and 7.4.

410 **7.2 Single platform model**

411 The physical Device exposes one or more logical Devices that are independently discoverable (i.e.
412 they separately respond to multicast discovery request messages as defined in clause 11.3 of
413 ISO/IEC 30118-1:2018). Given the door example there could be a single discovery response with
414 an instance of "/oic/d" that exposes a single Device Type (such as "oic.d.door") or multiple
415 discovery responses, each response having a single Device Type in the "rt" of "/oic/d" that
416 represents the logical Device. The common denominator being that for all discovered logical
417 Devices the Properties of "/oic/p" have the same values.

418 **7.3 Multi-platform model**

419 Just like the single-Platform model, one or more logical Devices that make up a physical Device
420 respond independently to multicast discovery request messages and expose their own Resources.
421 Like the single-platform model, each logical Device exposes a single Device Type in the "rt" value
422 of "/oic/d". The difference from the single-platform model is that each logical Device does not have
423 the same values for the Properties of "oic/p".

424 **7.4 Composite device model**

425 When modelling a Server as a Composite Device there shall be a single Platform which represents
426 the Composite Device. The Resource Type Property Value of "/oic/d" exposed should contain all
427 of the Device Types of the Devices that compose the Composite Device. For each Device that is
428 part of the Composite Device when using this approach there shall exist a Collection that represents
429 one of the distinct Devices in the composition. Further each Collection shall have a Resource Type
430 that at a minimum includes the Device Type that the Collection represents (e.g. ["oic.d.door"]).

431 Figure 2 illustrates the response to a discovery request using the baseline Interface on "/oic/res"
432 for a Composite Device modeled as described in this clause. Figure 3 illustrates the response to a
433 unicast RETRIEVE request using the baseline Interface to the Collection that represents the door
434 Device.

435

```

[
  {
    "rt": ["oic.wk.res"],
    "if": ["oic.if.baseline", "oic.if.ll" ],
    "links":
      [
        {
          "anchor": "ocf://dc70373c-1e8d-4fb3-962e-017eaa863989",
          "href": "/oic/d",
          "rt": ["oic.wk.d","oic.d.door","oic.d.sensor","oic.d.lock","oic.d.camera"],
          "if": ["oic.if.r","oic.if.baseline"],
          "p": {"bm": 3},
          "eps": [{"ep": "coap://[fe80::b1d6]:1111"}]
        },
        {
          "anchor": "ocf://dc70373c-1e8d-4fb3-962e-017eaa863989",
          "href": "/mydevice/mydoor",
          "rt": ["oic.d.door"],
          "if": ["oic.if.ll","oic.if.baseline","oic.if.r"],
          "p": {"bm": 3},
          "eps": [{"ep": "coaps://[fe80::b1d6]:1111"}]
        },
        {
          "anchor": "ocf://dc70373c-1e8d-4fb3-962e-017eaa863989",
          "href": "/mydevice/mysensor",
          "rt": ["oic.d.sensor"],
          "if": ["oic.if.ll","oic.if.baseline","oic.if.r"],
          "p": {"bm": 3},
          "eps": [{"ep": "coaps://[fe80::b1d6]:1111"}]
        },
        {
          "anchor": "ocf://dc70373c-1e8d-4fb3-962e-017eaa863989",
          "href": "/mydevice/mylock",
          "rt": ["oic.d.lock"],
          "if": ["oic.if.ll","oic.if.baseline","oic.if.r"],
          "p": {"bm": 3},
          "eps": [{"ep": "coaps://[fe80::b1d6]:1111"}]
        },
        {
          "anchor": "ocf://dc70373c-1e8d-4fb3-962e-017eaa863989",
          "href": "/mydevice/mycamera",
          "rt": ["oic.d.camera"],
          "if": ["oic.if.ll","oic.if.baseline","oic.if.r"],
          "p": {"bm": 3},
          "eps": [{"ep": "coaps://[fe80::b1d6]:1111"}]
        }
      ]
  }
]

```

Figure 2 – Example composite device model

```

{
  "rt": ["oic.d.door"],
  "if": ["oic.if.ll", "oic.if.r", "oic.if.baseline"],
  "id": "unique_example_id",
  "di": "dc70373c-1e8d-4fb3-962e-017eaa863989",
  "icv": "ocf.1.3.0",
  "dmv": "ocf.res.1.3.0, ocf.sh.1.3.0",
  "piid": "6F0AAC04-2BB0-468D-B57C-16570A26AE48",
  "links": [
    {
      "href": "/mydoor/openlevel",
      "rt": ["oic.r.openlevel"],
      "if": ["oic.if.a", "oic.if.baseline"],
      "p": {"bm": 2},
      "eps": [
        {"ep": "coaps://[fe80::b1d6]:1122"}
      ]
    }
  ]
}

```

438 **Figure 3 – RETRIEVE response to example door from composite device model**

439 **8 Discovery**

440 **8.1 Endpoint discovery**

441 Clients may discover Servers by using the mechanisms defined by ISO/IEC 30118-1:2018 clause
 442 10. A Client may populate an "rt" query parameter with the Device Types that the Client wants to
 443 discover, or if no "rt" query parameter is provided then the search is for all available Device Types
 444 irrespective.

445 Devices may be discovered by Device Type or implemented Resource Type. This difference is
 446 conveyed by the population of any "rt" query parameter included as part of discovery (see clause
 447 11.3 of ISO/IEC 30118-1:2018).

448 The values that may be used for discovering a specific Device Type are listed in Table A.2. The
 449 values that may be used to discover a specific Resource Type are listed in clause 6 of ISO/IEC
 450 30118-4:2018.

451 The discovery process provides the base URI of the Device that is acting as a Server to the Client.
 452 The structure of the detected Device can then be retrieved by Resource Discovery.

453 **8.2 Resource discovery**

454 Clause intentionally left blank

455

456 **9 Security**

457 A Device shall implement the mandated Security Virtual Resources specified in the ISO/IEC 30118-
458 2:2018. Additionally, all exposed ISO/IEC 30118-4:2018 defined Resources shall be accessible via
459 at least one secure Endpoint (i.e. use of a "coaps" or "coaps+tcp" scheme locator within the "eps"
460 Parameter exposed by /oic/res; see ISO/IEC 30118-1:2018 clause 10.2.4). A Device shall not
461 expose ISO/IEC 30118-4:2018 defined Resources using unsecured Endpoints (i.e. "coap" or
462 "coap+tcp" scheme locator in the "eps" Parameter).

463 With the exception of those Resources related to Discovery that are explicitly identified by the
464 ISO/IEC 30118-1:2018 as not requiring secured access (see ISO/IEC 30118-1:2018 clause 11.3.4),
465 all other Resources defined in ISO/IEC 30118-1:2018 implemented in the Smart Home Device shall
466 be accessible via at least one secure Endpoint (i.e. use of a "coaps" or "coaps+tcp" scheme locator
467 within the "eps" Parameter exposed by /oic/res). Similarly, any Resources defined in ISO/IEC
468 30118-1:2018 that do not require unsecured access that are not listed in /oic/res shall also be
469 accessible via "coaps" or "coaps+tcp".

Annex A
(normative)

Device categories and device types

A.1 Device categories

Devices are grouped into Device Categories based on the Universal Device Classification (UDC) (see A Basic Classification System for Energy-Using Products--Universal Device Classification), all Device Categories are listed in Table A.1.

Table A.1 – List of device categories

Device Category Name	Description
Space Conditioning	Heating and cooling systems
Lighting	
Appliance	Also known as "white goods"; covers major appliances only.
Electronics	Personal electronics
Miscellaneous	Small appliances, other
Infrastructure	Physical building and infrastructure
Transportation	Vehicles, fixed devices that provide movement (e.g. Escalators)
Fitness	Includes lifestyle
Medical	
Personal Health	
Other	

A.2 Device types

The complete Universal Device Classification with Device Types per Device Category is provided in Table A.2. Note that not all Devices within the UDC classification have equivalent OCF defined Device Types. All defined Device Types are of the form "oic.d.<thing>" where <thing> is a single alphanumeric string (lower case [a..z],[0..9] only) no more than 24 characters in length giving a total maximum length of the Device Type of 32 characters. Where an abbreviated form of the Device Type is required (applicable only to population of a Wi-Fi beacon IE) then the "oic.d." portion of the Device Type may be omitted.

Table A.2 does not specify the mandatory resources that are implemented by an instance of such a Device Type; the set of applicable mandatory Resources is dependent on the application domain. In this document the following domains are specified: Smart Home, Healthcare. The "Reference" column in the table references vertical specific annexes where the Device Type is further refined (e.g. mandatory Resources).

Table A.2 – Per category list of device types

Device Category Name	UDC Device Name	Device Name	Device Type (Normative)	Reference
Space Conditioning	Unitary System	Air Conditioner	oic.d.airconditioner	B.1
	Boiler	Water Heater	oic.d.waterheater	B.1
	Furnace	Furnace	oic.d.furnace	

	Pump	Pump	oic.d.pump	
	Fan	Fan	oic.d.fan	B.1
	Condensing Unit	Condensing Unit	oic.d.condensingunit	
	Condenser	Condenser	oic.d.condenser	
	Humidifier	Humidifier	oic.d.humidifier	B.1
	Dehumidifier	Dehumidifier	oic.d.dehumidifier	B.1
	HVAC – Control	Thermostat	oic.d.thermostat	B.1
	HVAC - Other	HVAC	oic.d.hvac	
		Air Purifier	oic.d.airpurifier	B.1
		Air Quality Monitor	oic.d.airqualitymonitor	B.1
Lighting	Lighting - Controls	Lighting Controls	oic.d.lightingcontrol	
	Lighting - Other	Light	oic.d.light	B.1
Appliance	Airer	Airer	oic.d.airer	B.1
	Clothes Dryer	Dryer (Laundry)	oic.d.dryer	B.1
	Clothes Washer	Washer (Laundry)	oic.d.washer	B.1
		Clothes Washer Dryer	oic.d.washerdryer	B.1
	Dishwasher	Dishwasher	oic.d.dishwasher	B.1
	Freezer	Freezer	oic.d.freezer	B.1
	Ice Machine	Ice Machine	oic.d.icemachine	
	Indoor Garden	Indoor Garden	oic.d.indoorgarden	B.1
	Mattress	Mattress	oic.d.mattress	B.1
	Oven	Oven	oic.d.oven	B.1
	Range	Range	oic.d.range	
	Refrigerator	Refrigerator	oic.d.refrigerator	B.1
	Water Heater	Water Heater	oic.d.waterheater	B.1
	Water Purifier	Water Purifier	oic.d.waterpurifier	B.1
	Appliance – Other	Cooker Hood	oic.d.cookerhood	B.1
		Cooktop	oic.d.cooktop	B.1
		Steam Closet	oic.d.steamcloset	B.1
Electronics	Audio System	Audio System	oic.d.audiosystem	
	A/V Player	AV Player	oic.d.avplayer	
	Camera	Camera	oic.d.camera	B.1
	Computer – Desktop	Desktop PC	oic.d.desktoppc	

	Computer - Notebook	Notebook PC	oic.d.notebookpc	
	Computer - Server	Server	oic.d.server	
	Computer – Other	Computer	oic.d.pc	
	Data Storage	Data Storage Unit	oic.d.datastorageunit	
	Display	Display	oic.d.display	
	Electronics - Portable	Portable Electronics	oic.d.portableelectronics	
	Game Console	Game Console	oic.d.gameconsole	
	Imaging Equipment	3D Printer	oic.d.3dprinter	B.1
		Printer	oic.d.printer	B.1
		Printer Multi-Function	oic.d.multifunctionprinter	B.1
		Scanner	oic.d.scanner	B.1
	Musical Instrument	Musical Instrument	oic.d.musicalinstrument	
	Networking Equipment	Networking Equipment	oic.d.networking	
	Phone Handset	Handset	oic.d.handset	
	Receiver	Receiver	oic.d.receiver	B.1
	Set Top Box	Set Top Box	oic.d.stb	B.1
	Telephony	Telephony	oic.d.telephonydevice	
	Television	Television	oic.d.tv	B.1, B.4.1
	A/V - Other	Active Speaker	oic.d.speaker	
	Electronics – Other	Electronics	oic.d.smallelectrical	
Miscellaneous	Air Compressors	Air Compressor	oic.d.aircompressor	
	Bathroom Device	Bathroom General	oic.d.bathroomdevice	
	Battery Charger	Battery Charger	oic.d.batterycharger	
	Business Equipment	Business Equipment	oic.d.businessequipment	
	Cleaning Equipment	Robot Cleaner	oic.d.robotcleaner	B.1
	Cooking – Portable	Portable Stove	oic.d.portablestove	
	Exercise Machine	Exercise Machine	oic.d.exercisemachine	
	HVAC – Portable	Portable HVAC	oic.d.hvacportable	

	Industrial	Optical augmented RFID Reader	oic.d.orfid	D.1
	Kitchen	Coffee Machine	oic.d.coffeemachine	B.1
		Food Probe	oic.d.foodprobe	B.1
		Grinder	oic.d.grinder	B.1
		Kettle	oic.d.kettle	B.1
	Lighting – Decorative	Decorative Lighting	oic.d.lightdecorative	
	Lighting – Emergency	Emergency Lighting	oic.d.lightemergency	
	Microwave Oven	Microwave Oven	oic.d.microwave	B.1
	Vending Machine	Vending Machine	oic.d.vendingmachine	
	Water Dispenser	Water Dispenser	oic.d.waterdispenser	
	Miscellaneous - Other	Battery	oic.d.battery	B.1, E.3
Infrastructure	Breakers	Water Valve	oic.d.watervalve	B.1
	Doors/Windows	Blind	oic.d.blind	B.1
		Door	oic.d.door	B.1
		Garage Door	oic.d.garagedoor	B.1
		Smart Lock	oic.d.smartlock	B.1
		Window	oic.d.window	B.1
	Fireplace	Fireplace	oic.d.fireplace	
	Pump	Pump	oic.d.pump	
	Power - Portable	Energy Generator	oic.d.energygenerator	B.1
		Smart Plug	oic.d.smartplug	B.1
	Power - Fixed	Arc Fault Circuit Interrupter	oic.d.afci	B.1
		Circuit Breaker	oic.d.circuitbreaker	E.3
		Ground Fault Circuit Interrupter	oic.d.gfci	B.1
		Inverter	oic.d.inverter	E.3
		PV Array System	oic.d.pvarraysystem	E.3
		Switch	oic.d.switch	B.1
	Security	Security Panel	oic.d.securitypanel	B.1
	Sensors	Generic Sensor	oic.d.sensor	B.1
	Meter	Electric Meter	oic.d.electrictmeter	B.1
		Energy Monitor	oic.d.energymonitor	B.1

Transportation	Transport - Other	Electric Vehicle Charger	oic.d.electricvehiclecharger	B.1
Fitness		Fitness Device	oic.d.fitnessdevice	
		Activity Tracker	oic.d.activitytracker	C.4
		Blood Pressure Monitor	oic.d.bloodpressuremonitor	C.4
		Body Thermometer	oic.d.bodythermometer	C.4
		Cycling Power Meter	oic.d.cyclingpowermeter	C.4
		Cycling Speed Sensor	oic.d.cyclingspeedsensor	C.4
		Cycling Cadence Sensor	oic.d.cyclingcadencesensor	C.4
		Heart Rate Monitor	oic.d.heartratemonitor	C.4
		Muscle Oxygen Monitor	oic.d.muscleoxygenmonitor	C.4
Medical		Blood Pressure Monitor	oic.d.bloodpressuremonitor	C.4
		Body Scale	oic.d.bodyscale	C.4
		Body Thermometer	oic.d.bodythermometer	C.4
		CGM	oic.d.cgm	C.4
		Glucose Meter	oic.d.glucosemeter	C.4
		Heart Rate Monitor	oic.d.heartratemonitor	C.4
		Medical Device	oic.d.medicaldevice	
		Pulse Oximeter	oic.d.pulseoximeter	C.4
		Sleep Monitor	oic.d.sleepmonitor	C.4
Personal Health		Activity Tracker	oic.d.activitytracker	C.4
		Blood Pressure Monitor	oic.d.bloodpressuremonitor	C.4
		Body Composition Analyser	oic.d.bodycompositionanalyser	C.4
		Body Scale	oic.d.bodyscale	C.4
		Body Thermometer	oic.d.bodythermometer	C.4
		CGM	oic.d.cgm	C.4
		Glucose Meter	oic.d.glucosemeter	C.4
		Heart Rate Monitor	oic.d.heartratemonitor	C.4
		Personal Health Device	oic.d.personalhealthdevice	

		Pulse Oximeter	oic.d.pulseoximeter	C.4
		Sleep Monitor	oic.d.sleepmonitor	C.4
Other	Other		oic.d.unknown	
		Access Management Service	oic.d.ams	
		Credential Management Service	oic.d.cms	
		Device Ownership Transfer Service	oic.d.dots	

Annex B
(normative)

Smart home device types

B.1 Smart home required resources per device type

Device Types may mandate that specific Resources be implemented. The required Resource per Device Type where mandated is listed in Table B.1. Additionally, specific Resources that use enumeration values to indicate supported states or modes may mandate usage of standardized enumeration values. The mandated allowed values are indicated for each applicable Resource Type, the Property of interest on that Resource Type and to which Device Type it applies.

Per Table B.1, some Device types support two instances of the same Resource Type. When this is the case, the Resources shall support different CRUDN actions, e.g. one Resource acts as a Sensor (CRUDN action write not supported) and the other Resource acts as an Actuator (CRUDN actions read and write supported at a minimum) unless otherwise specified.

Table B.1 – Alphabetical list of device types ("rt"), including required resources for smart home

Device Name (informative)	Device Type ("rt") (Normative)	Required Resource name	Required Resource Type
3D Printer	oic.d.3dprinter	Binary Switch	oic.r.switch.binary
		3D Printer	oic.r.printer.3d
		Operational State	oic.r.operational.state
		Temperature	oic.r.temperature
		Print Queue	oic.r.printer.queue
Active Speaker	oic.d.speaker	Binary Switch	oic.r.switch.binary
		Audio Controls	oic.r.audio
Airer	oic.d.airer	Binary Switch	oic.r.switch.binary
		Linear Movement Controls	oic.r.movement.linear
Air Conditioner	oic.d.airconditioner	Binary Switch	oic.r.switch.binary
		Temperature	oic.r.temperature
Air Purifier	oic.d.airpurifier	Binary Switch	oic.r.switch.binary
Air Quality Monitor	oic.d.airqualitymonitor	Air Quality Collection	oic.r.airqualitycollection
Arc Fault Circuit Interrupter	oic.d.afci	Fault Interrupter Switch	oic.r.switch.fault
Battery	oic.d.battery	Battery	oic.r.battery
Blind	oic.d.blind	Open Level	oic.r.openlevel
Camera	oic.d.camera	Media	oic.r.media
Clothes Washer Dryer	oic.d.washerdryer	Binary Switch	oic.r.switch.binary
		Operational State	oic.r.operational.state
Coffee Machine	oic.d.coffeemachine	Binary Switch	oic.r.switch.binary
		Operational State	oic.r.operational.state
Cooker Hood	oic.d.cookerhood	Airflow Control	oic.r.airflowcontrol

		Binary Switch	oic.r.switch.binary
		Mode	oic.r.mode
Cooktop	oic.d.cooktop	Heating Zone Collection	oic.r.heatingzonecollection
Dehumidifier	oic.d.dehumidifier	Binary Switch	oic.r.switch.binary
		Humidity	oic.r.humidity
Dishwasher	oic.d.dishwasher	Binary Switch	oic.r.switch.binary
		Mode	oic.r.mode
Door	oic.d.door	Open Level	oic.r.openlevel
Dryer (Laundry)	oic.d.dryer	Binary switch	oic.r.switch.binary
		Operational State	oic.r.operational.state
Electric Vehicle Charger	oic.d.electricvehiclecharger	Binary Switch	oic.r.switch.binary
		Operational State	oic.r.operational.state
		Battery	oic.r.battery
		Vehicle Connector	oic.r.vehicleconnector
Electric Meter	oic.d.electrictmeter	Energy Consumption	oic.r.energy.consumption
Energy Generator	oic.d.energygenerator	Energy Generation	oic.r.energy.generation
Energy Monitor	oic.d.energymonitor	One of: Energy Consumption, Gas Consumption	oic.r.energy.consumption or oic.r.gas.consumption
Fan	oic.d.fan	Binary Switch	oic.r.switch.binary
Food Probe	oic.d.foodprobe	Temperature (Sensor)	oic.r.temperature
Freezer	oic.d.freezer	Temperature(2)(1 Sensor and 1 Actuator)	oic.r.temperature
Garage Door	oic.d.garagedoor	Door	oic.r.door
Generic Sensor	oic.d.sensor	Any Resource Type that supports and exposes in "/oic/res" the oic.if.s interface.	oic.r. <x> Where this equates to any Resource Type that supports the oic.if.s Interface.
Grinder	oic.d.grinder	Operational State	oic.r.operational.state
		Grinder Settings	oic.r.grinder
Ground Fault Circuit Interrupter	oic.d.gfci	Fault Interrupter Switch	oic.r.switch.fault
Humidifier	oic.d.humidifier	Binary Switch	oic.r.switch.binary
Kettle	oic.d.kettle	Binary Switch	oic.r.switch.binary
Light	oic.d.light	Binary Switch	oic.r.switch.binary
Indoor Garden	oic.d.indoorgarden	Binary Switch	oic.r.switch.binary
Mattress	oic.d.mattress	Binary Switch	oic.r.switch.binary
		Mode	oic.r.mode
Oven	oic.d.oven	Binary Switch	oic.r.switch.binary
		Temperature (2) (1 Sensor and 1 Actuator)	oic.r.temperature

Printer	oic.d.printer	Binary Switch	oic.r.switch.binary
		Operational State	oic.r.operational.state
Printer Multi-Function	oic.d.multifunctionprinter	Binary switch	oic.r.switch.binary
		Operational State (2) ^a	oic.r.operational.state
		Automatic Document Feeder	oic.r.automaticdocumentfeeder ^b
Receiver	oic.d.receiver	Binary Switch	oic.r.switch.binary
		Audio Controls	oic.r.audio
		Media Source List (2)	oic.r.media.input, oic.r.media.output
Refrigerator	oic.d.refrigerator	Temperature (2) (1 Sensor and 1 Actuator)	oic.r.temperature
Robot Cleaner	oic.d.robotcleaner	Binary Switch	oic.r.switch.binary
		Mode	oic.r.mode
Scanner	oic.d.scanner	Binary Switch	oic.r.switch.binary
		Operational State	oic.r.operational.state
		Automatic Document Feeder	oic.r.automaticdocumentfeeder
Security Panel	oic.d.securitypanel	Mode	oic.r.mode
Set Top Box	oic.d.stb	Binary Switch	oic.r.switch.binary
Smart Lock	oic.d.smartlock	Lock Status	oic.r.lock.status
Smart Plug	oic.d.smartplug	Binary Switch	oic.r.switch.binary
Steam Closet	oic.d.steamcloset	Operational State	oic.r.operational.state
		Time Period	oic.r.time.period
Switch	oic.d.switch	Binary Switch	oic.r.switch.binary
Television	oic.d.tv	Binary Switch	oic.r.switch.binary
		Audio Controls	oic.r.audio
		Media Source List	oic.r.media.input
Thermostat	oic.d.thermostat	Temperature (2) (1 Sensor and 1 Actuator)	oic.r.temperature
Washer (Laundry)	oic.d.washer	Binary Switch	oic.r.switch.binary
		Operational State	oic.r.operational.state
Water Heater	oic.d.waterheater	Binary Switch	oic.r.switch.binary
		Temperature(2) (1 Sensor and 1 Actuator)	oic.r.temperature
Water Purifier	oic.d.waterpurifier	Operational State	oic.r.operational.state
		Water Info	oic.r.waterinfo
Water Valve	oic.d.watervalve	Open Level	oic.r.openlevel
Window	oic.d.window	Open Level	oic.r.openlevel

^a A Multi-Function Printer shall expose two instances of an Operational State resource; each in discrete Collections, one for the Printer specific operational state information and one for the Scanner specific operational state information. The friendly name for the Collections should indicate the device modality (printer or scanner).

b A Multi-Function Printer shall only expose an Automatic Document Feeder resource if the device has the Automatic Document Feeder capability.

509 **B.2 Standardized enumeration values**

510 **B.2.1 Introduction**

511 Resource Types may have a list of supported enumeration values. The supported enumeration
 512 values may differ when applied in different devices. In this clause the affected Resource Types are
 513 described by:

- 514 – Generic list of supported values
- 515 – Mandated list of supported values when applied to a specific Device

516 **B.2.2 Alphabetical list of standardized enumeration types**

517 Table B.2 lists the standardized enumeration types that may be present within Resource Properties
 518 where the Property is defined as containing values from this clause. The enumerations also apply
 519 to Semantic Tags (see ISO/IEC 30118-1:2018) where the tag is defined as containing values from
 520 this clause.

521 **Table B.2 – The defined set of standardized enumerations**

Enumeration	Description
aborted	An internal device, communication or security error
active	Unit is active
airClean	unit is in air clean mode or state
airDry	unit is air drying
airfilterconsumable	identifies the main air filter consumable ("oic.r.consumable") Resource of the Device
airflow	Identifies the main airflow ("oic.r.airflow") Resource of the Device
airpurifierswitch	identifies that the switch ("oic.r.switch.binary") can turn on/off the air purifying function of the Device
airqualityairpollution	identifies the air quality ("oic.r.airquality") Resource measuring (total) air pollution
airqualityodor	identifies the air quality ("oic.r.airquality") Resource measuring odor
airqualitypm1	identifies the air quality ("oic.r.airquality") Resource measuring pm1
airqualitypm10	identifies the air quality ("oic.r.airquality") Resource measuring pm10
airqualitypm2.5	identifies the air quality ("oic.r.airquality") Resource measuring pm2.5
ambient	unit is in ambient mode or state
alarmtimeperiod	identifies the duration time for an alarm ("oic.r.time.period")
armedAway	unit is armed for away
armedInstant	unit is armed instantly
armedMaximum	unit is armed at maximum level
armedNightStay	unit is armed in night stay
armedStay	unit is armed in stay mode
aroma	unit is armed in aroma mode

artificialintelligence	unit is in artificial intelligence mode
auto	unit is in auto mode or state
awning	identifies that the instance of "oic.r.windowcovering" represents an awning
babyCare	unit is in baby care mode or state
baking	unit is in baking mode or state
battery	identifies the main battery ("oic.r.battery") Resource of the Device
boiling	unit is in boiling state or mode
brewing	unit is in brewing state or mode
cancelled	the job was cancelled either by the remote client or by the user
changeCondition	the unit has experienced a change in condition, mode or state
charging	the unit is in charging mode or state
checkingTurbidity	unit is in checking turbidity state
circulating	unit is in circulating model or state
cleaning	unit is in cleaning mode or state
clothes	unit is in clothes mode
completed	job finished successfully
contactsensor	identifies an "Intruder Alert Zone" ("oic.r.iaszoneinfo") type of contact sensor
convenientroomdoor	identifies the convenient room door ("oic.r.door") of the refrigerator ("oic.d.refrigerator")
convertible	unit is for a convertible part (among compartments of a refrigerator). User can configure the parts as desired
convBake	unit is in convection bake mode
convRoast	unit is in convection roast mode
cool	unit is in cooling mode or state
coolingtargettemperature	identifies the target cooling temperature ("oic.r.temperature") Resource of the air conditioner ("oic.d.airconditioner")
coolerdoor	identifies the cooler door ("oic.r.door") of the Device
coolermeasuredtemperature	identifies the measured cooler temperature ("oic.r.temperature") Resource of the Device
coolertargettemperature	identifies the target cooler temperature ("oic.r.temperature") Resource of the Device
cosensor	identifies an "Intruder Alert Zone" ("oic.r.iaszoneinfo") type of carbon monoxide sensor
currenttemperature	identifies the current measured temperature ("oic.r.temperature") Resource of the Device
delicate	unit is in delicate mode or state
deodorization	identifies the main deodorization ("oic.r.deodorization") Resource of the Device
diagnosis	unit is in diagnosis mode or state; when an error occurs, a Device is in diagnosis mode (state) for identifying causes and finding solutions
disabled	unit's current operational mode is disabled

dishwasherdoor	identifies the main door ("oic.r.door") Resource of the Dish Washer ("oic.d.dishwasher")
down	unit is unavailable
drapery	identifies that the instance of "oic.r.windowcovering" represents drapery
dry	unit is dry mode
dual	unit is in dual mode
ecomode	identifies the main (overall) ecomode ("oic.r.ecomode") Resource of the Device
edge	unit is edge mode or state
enabled	unit's current operational mode is enabled
express	unit is in express mode or state
extended	unit is in extended mode or state
fan	unit is in fan mode or state
fast	unit is in fast mode or state
filterMaterial	filter material that is used by a Device
firesensor	identifies an "Intruder Alert Zone" ("oic.r.iaszoneinfo") type of fire sensor
focused	unit is in focused mode or state
foot	unit is in foot mode or state
freezePrevent	unit is in freeze prevent mode or state
freezePreventPending	unit is pending freeze prevent mode
freezePreventPause	unit is in the paused state while in freeze prevent mode
freezer	unit is for a freezer part (among compartments of a refrigerator)
freezerdoor	identifies the freezer room door ("oic.r.door") Resource of the Device
freezermeasuredtemperature	identifies the measured freezer temperature ("oic.r.temperature") of the Device
freezertargettemperature	identifies the target freezer temperature ("oic.r.temperature") of the Device
fridge	unit is for a fridge part (among compartments of a refrigerator)
glassbreaksensor	identifies an "Intruder Alert Zone" ("oic.r.iaszoneinfo") type of glass break sensor
grinding	unit is in grinding state or mode
healing	unit is in healing mode or state
heating	unit is in heating mode or state
heatingtargettemperature	identifies the target heating temperature ("oic.r.temperature") of the Device
heavy	unit is in heavy mode or state
homing	unit is in homing state, Device produces a special signal so that it can be found using electronic equipment
hot	unit is in hot mode or state
humidify	unit is in humidify mode or state
humidity	identifies the main humidity ("oic.r.humidity") Resource of the Device

ice	unit is in ice mode or state
idle	new jobs can start processing without waiting
initializing	unit is in initializing state, a Device resets its values set by a Client to initial values set by manufacturer
ink	generic ink cartridge for a Device
inkBlack	black ink cartridge for a Device
inkCyan	cyan ink cartridge for a Device
inkMagenta	magenta ink cartridge for a Device
inkTricolour	tricolour ink cartridge for a Device
inkYellow	yellow ink cartridge for a Device
invalid	unit is in an invalid mode, state, or setting
keepwarm	unit is in keep warm state or mode
keyfob	identifies an "Intruder Alert Zone" ("oic.r.iaszoneinfo") type of key fob
keypad	identifies an "Intruder Alert Zone" ("oic.r.iaszoneinfo") type of keypad
localtime	identifies the clock ("oic.r.clock") time representing the local time zone
macro	unit is in macro mode or state, Client manually inputs a rule or pattern of operation
main	unit is part of the main device or is the main device
mapping	unit is in mapping mode or state
mineral	unit is in mineral mode
monitoring	unit is in monitoring mode or state; such as security functions detecting unusual movements in an empty place for a camera-mounted Device
monitoringInitializing	unit is in initializing state in monitoring mode; a Device resets its values of monitoring mode to initial values set by manufacturer
monitoringMoving	unit is in moving state in monitoring mode; following a specific target that client select while the Device is in monitoring mode
monitoringPreparation	unit is in preparation state in monitoring mode; a Device is getting ready for its monitoring operation
morning	unit is in morning mode or state
motionsensor	identifies an "Intruder Alert Zone" ("oic.r.iaszoneinfo") type of motion sensor
moving	unit is in moving state; the action of going to a different place
night	unit is in night-time mode or state
nightDry	unit is in night-time drying mode or state
none	unit is in an undefined mode or state
normal	unit is in a normal operational state
notsupported	ability to set a specific operational mode by a Client is not supported
onedoorfridgedoor	identifies the single door ("oic.r.door") of the Device
operationalstate	identifies the main (overall) operational state ("oic.r.operational.state") of the Device

operationalmode	identifies the main (overall) mode ("oic.r.mode") of the Device
pause	unit is paused (by user)
ped	identifies an "Intruder Alert Zone" ("oic.r.iaszoneinfo") type of personal emergency device
pending	job initiated, engine is preparing
pendingHeld	job is not a candidate for processing for any number of reasons, will return to pending state if reasons are solved
permapress	unit is in permanent press mode or state
powerswitch	identifies the Resource that is the main power switch ("oic.r.switch.binary"), e.g. on/off of the Device
preHeat	unit is in pre-heat mode or state
preparation	unit is in preparation mode or state; a Device is getting ready for its operation
preSteam	unit is in pre-steam mode or state
preWash	unit is pre wash mode
processing	processing the job
projectorscreen	identifies that the instance of "oic.r.windowcovering" represents a projector screen
pure	unit is in pure mode or state
quick	unit is in quick mode or state
quiet	unit is in quiet mode
refresh	unit is in refresh mode or state
refrigeration	identifies the main ("oic.r.refrigeration") Resource of the Device
relativeremainingtimeperiod	identifies the Resource as (overall) relative remaining time period ("oic.r.time.period")
relax	unit is in relax mode or state
remainingtimeperiod	identifies the Resource as (overall) absolute remaining time period ("oic.r.time.period")
remotecontrol	identifies an "Intruder Alert Zone" ("oic.r.iaszoneinfo") type of remote control
remotecontrolenable	identifies the Resource for remote control enable ("oic.r.switch.binary"), e.g. remote enablement of the Device
reserve	unit is in reserve mode or state
reserving	unit is in reserving state
restart	unit is in re-start mode or state
ringing	unit is in ringing state to indicate alarm, emergency, caution, and so on
rinse	unit is in rinse mode or state
rollershade	identifies that the instance of "oic.r.windowcovering" represents a roller shade
rollershade2	identifies that the instance of "oic.r.windowcovering" represents a two motor roller shade
rollershadeext	identifies that the instance of "oic.r.windowcovering" represents an exterior roller shade

rollershadeext2	identifies that the instance of "oic.r.windowcovering" represents an exterior two moto roller shade
sectored	unit is in sectored mode or state
select	unit is in select mode or state
securityrepeater	identifies an "Intruder Alert Zone" ("oic.r.iaszoneinfo") type of security repeater
setOption	unit is in a state whereby device options may be set
shake	unit is in shake mode or state
shoesDry	unit is in shoes dry mode or state
shutter	identifies that the instance of "oic.r.windowcovering" represents a shutter
silent	unit is in silent mode or state
sleep	unit is in sleep mode or state
sleepreservationtimeperiod	identifies the Resource ("oic.r.time.period") as sleep reservation time
smart	unit is in smart mode or state
soaking	unit is in soaking mode or state
soda	unit is in soda mode
spin	unit is in spin mode or state
spot	unit is in spot mode or state
spray	unit is in spray mode or state
standardcie	identifies an "Intruder Alert Zone" ("oic.r.iaszoneinfo") type of standard control and indicator equipment
start	unit is in start mode or state
startreservationtimeperiod	identifies the Resource ("oic.r.time.period") as start of reservation time
steam	unit is in steam mode or state
steamSoftening	unit is in steam softening mode or state, whereby the fabric is softened using only water and no softening additives
sterilize	unit is in sterilize mode or state
stopreservationtimeperiod	identifies the Resource ("oic.r.time.period") as stop of reservation time
stopped	error condition occurred
stretching	unit is in stretching mode or state
subDevice	unit is for a sub-device that makes up part of a main device
swd	identifies an "Intruder Alert Zone" ("oic.r.iaszoneinfo") type of standard warning device
targettemperature	identifies the target (setpoint) temperature ("oic.r.temperature") of the Device
testing	calibrating, preparing the unit
tiltblind	identifies that the instance of "oic.r.windowcovering" represents a tilt only tilt blind
tiltblind2mode	identifies that the instance of "oic.r.windowcovering" represents a tilt and lift tilt blind
toner	generic toner cartridge for a Device

tonerBlack	black toner cartridge for a Device
tonerCyan	cyan toner cartridge for a Device
tonerMagenta	magenta toner cartridge for a Device
tonerYellow	yellow toner cartridge for a Device
turbo	unit is in turbo mode or state
update	unit is in update mode or state
vendorspecific	identifies an "Intruder Alert Zone" ("oic.r.iaszoneinfo") type that is specific to the manufacturer
vibrationsensor	identifies an "Intruder Alert Zone" ("oic.r.iaszoneinfo") type of vibration sensor
waiting	unit is in waiting mode or state
wakeup	unit is in wakeup state just after sleep mode
warm	unit is in warm mode or state
wash	unit is in wash mode or state
waterinfo	identifies the main water information ("oic.r.waterinfo") of the Device
waterfilterconsumable	identifies the main water filter consumable ("oic.r.consumable") of the Device
waterproofing	unit is in waterproofing mode or state
watersensor	identifies an "Intruder Alert Zone" ("oic.r.iaszoneinfo") type of water sensor
wet	unit is in wet mode or state
wind	unit is in wind mode
wrinklePrevent	unit is in wrinkle prevent mode
zigzag	unit is in zigzag mode or state

522

523 **B.2.3 Standardized list of supported values for mode resource type (oic.r.mode)**

524 Table B.3 lists per Device Type the supported enumeration values that can apply to both of the
525 Properties "supportedModes" and "modes" of the Mode Resource Type.

526 **Table B.3 – List of supported "oic.r.mode" values per Device Type ("rt")**

Device Name (informative)	Device Type (rt) (Normative)	Supported enumeration value	Description
Air Conditioner	oic.r.airconditioner	airClean	This removes contaminants from the indoor air.
		airDry	This removes moisture from the inside of the device to prevent mould after cooling air.
		aroma	This adds a deodorizing scent to make the air fresher.
		auto	This automatically selects and operates cooling and/or heating based on the current temperature condition.
		cool	This cools the indoor air.
		energySaving	This saves energy (electricity) by restricting some functions.
		fan	This circulates the inside air without cool and inflow of outside air.

Air Purifier	oic.d.airpurifier	auto	This is continuously checking the air quality and operating as needed to maintain good air quality.
		babyCare	This removes contaminants from indoor air and discharges clean air in a downward flow for babies and children.
		circulating	This circulates the inside air by using the fan inside the device.
		cleaning	This removes contaminants from the indoor air. In the case where the device consists of lower and upper sections, this function is operated only in the lower section.
		dual	This removes contaminants from the indoor air. In the case where the device consists of lower and upper sections, this function operates in both of sections.
		humidity	This increases moisture in the indoor air.
		silent	This reduces noise during the operation.
		sleep	This is a low power mode for the device to lower electrical consumption on standby.
Airer	oic.d.airer	airDry	This dries wet materials by using forced air (no heat).
		dry	This dries wet materials by using hot air.
		none	This is an undefined mode.
Dishwasher	oic.d.dishwasher	auto	This senses the soiled amount and soiled toughness and is optimized to achieve the best cleaning.
		cleaning	This means cleaning the inside of the device when there are no dishes.
		delicate	This is to clean delicate items (e.g., fine china, small plates, long cutlery, cups, glasses, and so on).
		energySaving	This saves energy by reducing the wash and rinsing temperature.
		express	This cleans lightly soiled dishes faster than "quick" mode.
		fast	This focuses on cleaning soiled dishes quickly.
		heavy	This cleans heavily soiled dishes with the strongest spray intensity.
		normal	This cleans soiled dishes for everyday use based on basic setting from manufacturers.
		quick	This quickly cleans the lightly soiled dishes used that were used recently.
		refresh	This is to freshen up and warm dishes that have been unused for a long time.
		rinse	This rinses dishes with water.
		spray	This provides selectable options for spray intensity. (For example, the options could be soft, medium, and strong)
		steam	This adds steam at the beginning of the cycle to improve the wash performance.
turbo	This cleans heavily soiled dishes by using slightly more energy and water.		

		update	This downloads a dedicated cycle via Wi-Fi, NFC, and so on.
Oven	oic.d.oven	baking	This cooks by dry heat in an oven
		convBake	This is a baking mode of a convection oven
		convRoast	This is a roasting mode of a convection oven
Robot Cleaner	oic.d.robotcleaner	edge	This is cleaning the outside perimeter of the area.
		macro	This is cleaning specific areas manually selected by a client.
		sectored	This is cleaning complex areas by dividing the cleaning area into sections.
		select	This is cleaning areas selected by a client among divided sections of the indoor.
		spot	This is cleaning a small area within the radius of the manufacturer's default set.
		zigzag	This is cleaning each spot of indoor by moving zigzag.
Security Panel	oic.d.securityPanel	active	
		armedAway	
		armedInstant	
		armedMaximum	
		armedNightStay	
		armedStay	

527 The modes can be viewed upon as mode changes of the device. However, this document does not
528 impose any relationship between the different modes of a Device. Hence all mode changes are
529 expected to occur from a Client point of view.

530 Figure B.1 provides an illustrative example of a possible set of modes and the transitions between
531 them for a Dryer Device Type (oic.d.dryer).

An example mode transition diagram of a Dryer, not all mode transitions are listed.

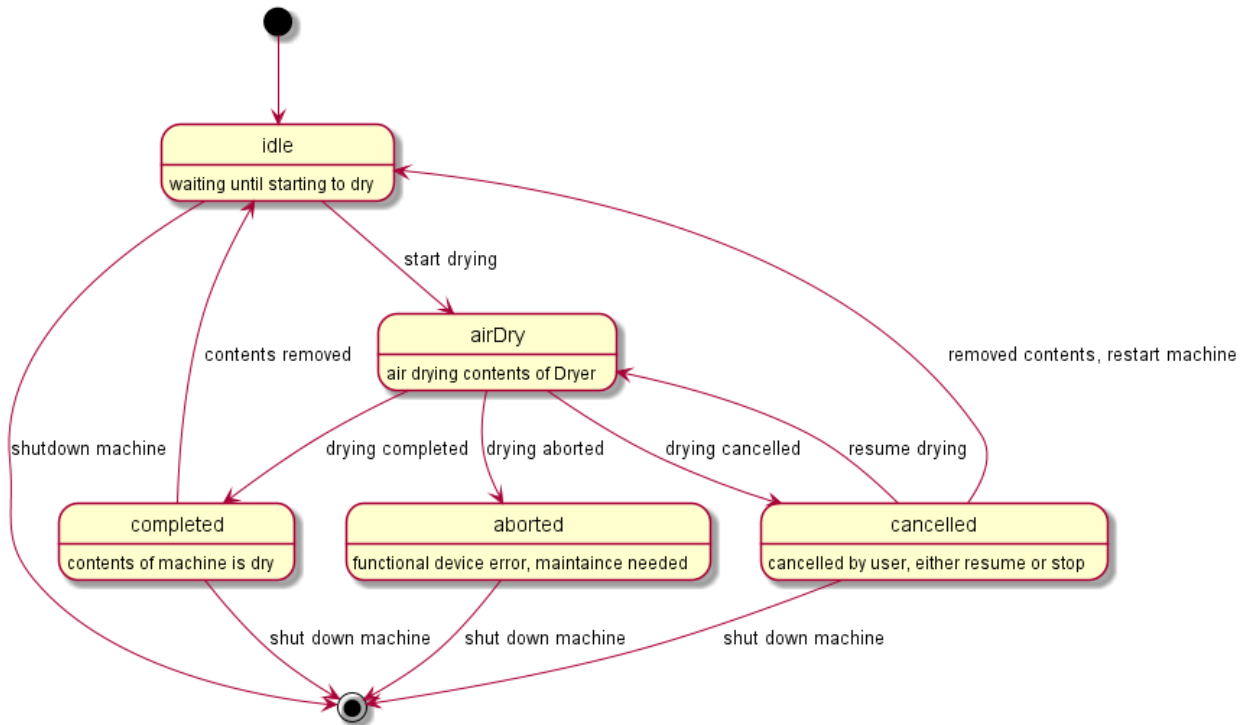

532

533

534

Figure B.1 – Example of mode transitions of a dryer

535

B.2.4 Standardized list of supported values for operational state resource type (oic.r.operational.state)

537

Table B.4 lists the supported enumeration values per Device Type for the Property “machineStates” of the operational state Resource Type.

538

Table B.4 – List of supported "oic.r.operational.state" values per Device Type ("rt")

540

Device Name (informative)	Device Type (rt) (Normative)	Supported enumeration value machineStates
Dishwasher	oic.d.dishwasher	start
		stop
Dryer	oic.d.dryer	start
		stop
Oven	oic.d.oven	completed
		preHeat
		start
Printer	oic.d.printer	idle
		processing
		stopped
Printer Multi-Function	oic.d.multifunctionPrinter	See Printer
		See Scanner

Robot Cleaner	oic.d.robotcleaner	homing
		pause
		restart
		start
		wakeUp
Scanner	oic.d.scanner	down
		idle
		processing
		stopped
		testing
Steam Closet	oic.d.steamcloset	start
		stop
		wakeUp
Washer	oic.d.washer	start
		stop
		wakeUp

541

542 Table B.5 lists the supported enumeration values per Device Type for the Property “jobStates” of
543 the operational state Resource Type.

544 **Table B.5 – List of supported values per Device Type (“rt”) for jobStates of operational**
545 **state resource type**

Device Name (informative)	Device Type (rt) (Normative)	Supported enumeration value jobStates	Description
Dishwasher	oic.d.dishwasher	aborted	This is an internal device, communication, or security error. (e.g. power_fail)
		airDry	This dries wet materials by using forced air (no heat).
		cancelled	This state is cancelled by (remote) user.
		completed	This state is a job completed without any error.
		down	This state is unavailable to operate a job due to some issues. (e.g. power_off)
		nightDry	This runs the ventilation fan periodically to vent the steam from the tub. Because the dishes are often left in the dishwasher overnight after the cycle ends, this can result in the steam inside the tub condensing on the dishes, leaving them wet. To prevent the above state, the device can provide this state.
		pause	This state is paused by user.
		pending	This state is waiting that the device prepares to initiate a job.
		reserve	This state means that a client has finished setting the system for future use.
		rinse	This is to rinse the dishes with water

		wash	This is to clean the soiled dishes
Dryer	oic.d.dryer	aborted	This is an internal device, communication, or security error.
		airDry	This dries the materials by using forced air (no heat).
		completed	This state is a job completed without any error.
		coolDown	This state is for the temperature cool down to reduce clothes temperature' by spinning the interior drum without heat.
		diagnosis	When an error occurs, the device enters this state to identify causes and find solutions.
		down	This state is device unavailable to operate a job due issues. (e.g. power_off)
		pause	This state is paused by user.
		pending	This state is waiting that the device prepares to initiate a job.
		processing	This is working on a job executed by a client.
		reserve	This state means that a client has finished setting the system for future use.
		wrinklePrevent	This state runs the dryer periodically to help prevent wrinkles from forming.
Oven	oic.d.oven	cleaning	This is cleaning to remove the soiled inside and outside of the device.
		completed	This state is job completed without any error.
		cool	This is cooling the temperature inside and outside of the device after finishing cooking.
		down	This state is unavailable to operate a job due to issues. (e.g. power_off)
		idle	This means that new jobs can start processing without waiting. (e.g., preheating is done)
		pause	This state is paused by user.
		pending	This state is waiting that the engine prepares to initiate a job.
		preHeat	This is pre-heating the inside of the device prior to cooking.
		processing	This is working on a job executed by a user.
		setOption	This is in status while being set for the device's options.
Printer	oic.d.printer	aborted	This is in internal device, communication, or security error.
		cancelled	This state is cancelled by (remote) user.
		completed	This state is job completed without any error.
		pending	This state is waiting that the device prepares to initiate a job.
		pendingHeld	This state halts pending from processing for any number of reasons. This will return to pending state if the issues are resolved.
		processing	This is working on a job executed by a client.

Printer Multi-Function	oic.d.multifunction Printer	See printer	Refer to the supported enumeration values of a Printer (oic.d.printer).
		See scanner	Refer to the supported enumeration values of a Scanner (oic.d.scanner).
Robot Cleaner	oic.d.robotcleaner	charging	This means that the device is charging. In the case of robot cleaner, it can be charged by connecting with its home station.
		cleaning	This is cleaning indoor floor with selected mode by a client.
		diagnosis	When an error occurs, a device enters this state to identify causes and find solutions.
		homing	This state means that the device is moving to its home station after finishing work or to charging its battery
		idle	This means that new jobs can start processing without waiting.
		initializing	This is resetting device to initial values set by manufacturer.
		macro	This is controlled and cleaned by the client based on a remote controller.
		mapping	At first use of the device, it scans the indoor area by moving to make a map.
		monitoring	This is a security functions detecting strange movements in an empty place by using mounted cameras.
		monitoringInitializing	This is resetting device to initial values set by the manufacturer.
		monitoringMoving	This is moving to follow a specific target that a user selects while the device is in monitoring mode.
		monitoringPreparation	This is in a state where a device is getting ready for its monitoring operation.
		moving	This is moving to go to a different place.
		pause	This state is paused by user.
		preparation	This means that the device is getting ready for its operation.
		reserving	This state means that a client is setting systems for future use.
		setOption	This is the status while being set for the device's options.
Scanner	oic.d.scanner	aborted	This is in internal device, communication, or security error.
		cancelled	This state is cancelled by (remote) user.
		completed	This state is completely finished the job without any error.
		pending	This state is waiting that the device prepares to initiate a job.
		processing	This is working on a job executed by a client.
Steam Closet	oic.d.steamcloset	aborted	This is an internal device, communication, or security error.
		airDry	This is in drying the materials by using wind.
		completed	This state is job completed without any error.

		diagnosis	When an error occurs, a device enters this state to identify causes and find solutions.
		down	This state is unavailable to operate a job due to issues (e.g. power_off)
		idle	This means that new jobs can start processing without waiting (e.g. washing is done).
		initializing	This is resetting device to initial values set by manufacturer.
		nightDry	This is a special sanitary care during the night, which runs heavy sanitary care and then dries periodically every hour for an additional eight hours.
		pause	This state is paused by user.
		pending	This state is waiting that the device prepares to initiate a job.
		preHeat	This is preheating the inside of the device.
		preSteam	This is steaming the inside of the device to remove residual material at the beginning of the cleaning sequence.
		processing	This is working on a job executed by a client.
		reserve	This state means that a client has finished setting the system for future use.
		shake	This is to quickly shake the hanger inside of the device to remove drops of water on clothes after a steam cycle.
		sleep	This is in low power state for the device to lower electrical consumption on standby.
		steam	This sprays steam on the washable items to remove odors and wrinkles after preheat the inside of the device.
		sterilize	This removes germs on items through high temperature and steam.
		update	This downloads a dedicated cycle via Wi-Fi, NFC, and so on.
Washer	oic.d.washer	aborted	This is an internal device, communication, or security error.
		changeCondition	After the washer checked the turbidity, the device could change condition progressing state. For example, the washer can rinse the clothes one more time or finish washing it.
		checkingTurbidity	The device automatically checks turbidity during rinsing the clothes to check if the detergent remains.
		completed	This state is completely finished the job without any error.
		coolDown	This state is temperature cool down to reduce clothes temperature' by spinning the interior drum without heat only in case the washer supports a dry function.
		diagnosis	When an error occurs, a device enters this state to identify causes and find solutions.
		down	This state is unavailable to operate a job due to issues. (e.g. power_off)

		dry	This is to dry the washed clothes with heat.
		freezePrevent	To prevent developing ice inside of the device and pipe, the device takes special care of the device condition in the winter.
		freezePreventPause	This is paused state in freeze prevent mode.
		freezePreventPending	This is pending state in freeze prevent mode.
		grinding	This is to grind debris to prevent drain pipes being clogged.
		idle	This means that new jobs can start processing without waiting. (e.g. rinsing clothes is done)
		pause	This state is paused by user.
		pending	This state is waiting that the device prepares to initiate a job.
		preparation	This means that the device is getting ready for its operation This state includes checking the amount of detergent, softener, water and so on.
		preWash	This is to wash heavily soiled clothes in advance before starting the washing process.
		processing	This is working on a job executed by a client.
		refresh	This removes wrinkles from slightly wrinkled clothes by using steam for if the washer supports steam function
		reserve	This state means that a client has finished setting the system for future use.
		rinse	This is to rinse the dishes with water.
		shoesDry	This is a special cycle for drying shoes.
		sleep	This is in low power state for the device to lower electrical consumption on standby.
		soaking	This makes clothes thoroughly wet by immersing them in liquid so dust and stains can easily be removed.
		spin	This is spinning fast to remove the water after completely rinsing the clothes.
		steam	This sprays steam on clothes to remove odors and wrinkles.
		steamSoftening	This softens the fabric using 100% pure water and no chemicals with steam instead of chemical fabric softeners.
		testing	This checks the amount of clothes inside the washer and displays the results.
		update	This downloads a dedicated cycle via Wi-Fi, NFC, and so on.
		wash	This is washing the clothes with selected cycle set by a client
		waterproofing	This washes (sports) clothes with a dedicated liquid for waterproofing.
		wrinklePrevent	This state can help prevent wrinkles from forming.

546 The operational state can be viewed as state changes of the device that includes separate handling
 547 of jobs within the overall machine state. However, this document does not impose any relationship
 548 between the different machine or job states of a device. Hence all "machinestate" and or "jobStates"
 549 changes are expected to occur from a Client point of view.

550 Figure B.2 provides an illustrative example of a possible set of job states and the transitions
 551 between them for a Printer Device Type ("oic.d.printer").

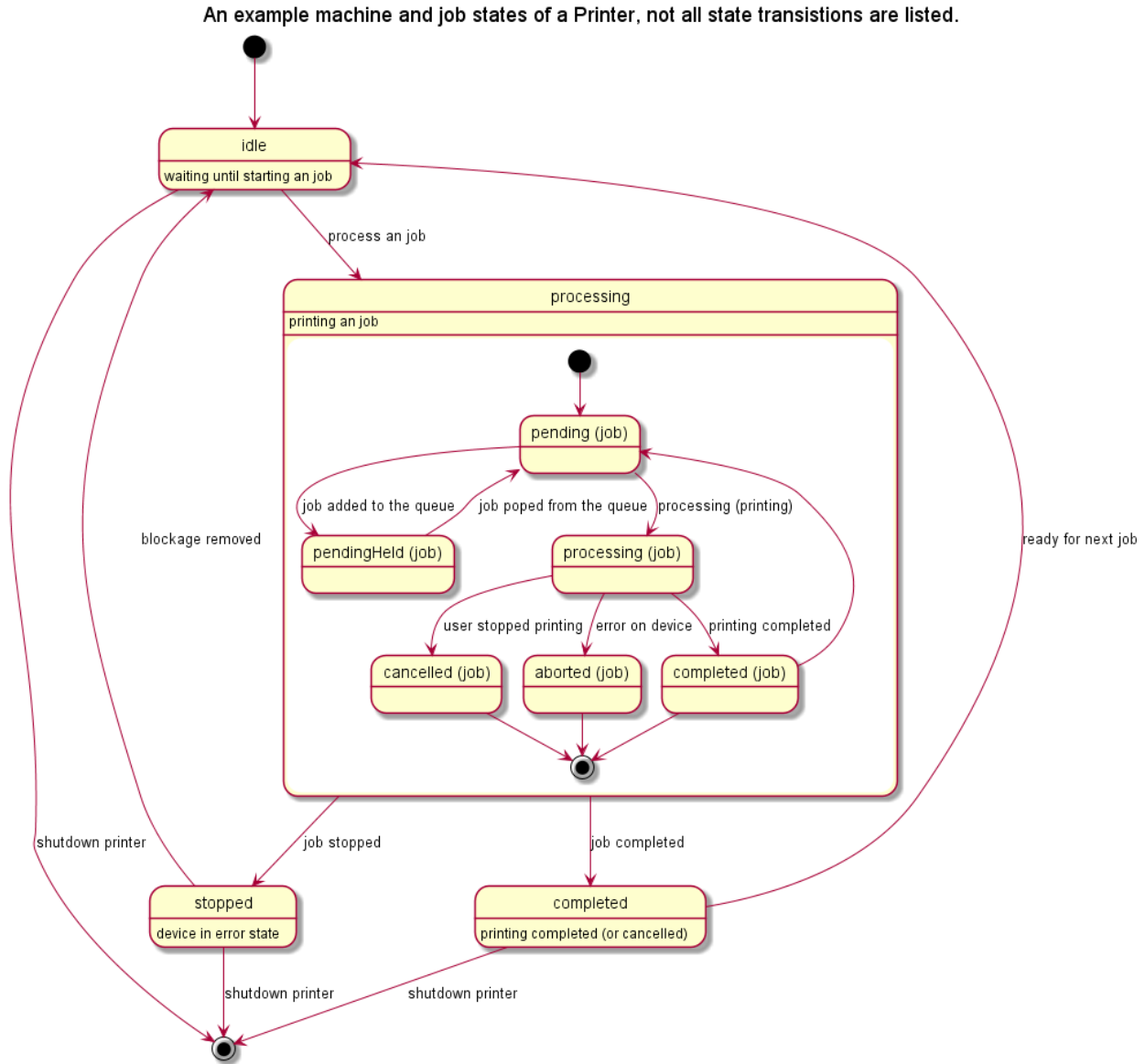

552

553

554 **Figure B.2 – Example of job state transitions of a printer**

555 **B.2.5 Standardized list of supported values for consumable and consumable collection**
 556 **resource types (oic.r.consumable, oic.r.consumablecollection)**

557 Table B.6 lists the enumeration values that may be populated in both the supportedconsumables
 558 (in oic.r.consumablecollection) and typeofconsumable (in oic.r.consumable) Properties within the
 559 Consumable and Consumable Collection Resource Types. The typeofconsumable Property shall

560 only be populated with a value exposed within the supportedconsumables Property in a specific
 561 instance of the Consumable Collection Resource Type.

562 This constitutes the known set of possible values for these Properties in the Consumable and
 563 Consumable Collection Resources. A vendor may extend this set by providing vendor defined
 564 enumerations following the convention defined in ISO/IEC 30118-4:2018.

565 **Table B.6 – List of defined enumeration values for oic.r.consumable,**
 566 **oic.r.consumablecollection**

Friendly Name (informative)	Enumeration Value (Normative)	Description (Informative)
Toner Cartridge	toner	Generic toner cartridge.
Black Toner Cartridge	tonerBlack	Black toner cartridge
Cyan Toner Cartridge	tonerCyan	Cyan toner cartridge
Magenta Toner Cartridge	tonerMagenta	Magenta toner cartridge
Yellow Toner Cartridge	tonerYellow	Yellow toner cartridge
Filter Material	filterMaterial	Any replaceable or reusable filter material; such as water filters, air filters, dust filters etc.
Ink Cartridge	ink	Generic ink cartridge
Black Ink Cartridge	inkBlack	Black ink cartridge
Cyan Ink Cartridge	inkCyan	Cyan ink cartridge
Magenta Ink Cartridge	inkMagenta	Magenta ink cartridge
Yellow Ink Cartridge	inkYellow	Yellow ink cartridge
Tricolour Ink Cartridge	inkTricolour	Tri-colour ink cartridge; typically Cyan plus Magenta plus Yellow.

567

568 **B.3 Camera media format (oic.r.media)**

569 The supported camera media formats can be discovered by looking at the SDP (see IETF RFC
 570 4566) list of the media Resource Type. The recommended list of supported media formats are listed
 571 in Table B.7.

572 **Table B.7 – Recommended media profiles**

Mediatype	codec	Content container format	transport	Additional information
Audio	AAC		RTP	
Video	H.264		RTP	Recommended minimal resolution 1920x1080 (width, height)
Video	H.264/AAC	MPEG-2 TS	RTP	Recommended minimal resolution 1920x1080 (width, height)
Still image	JPEG	JPEG	RTP	Recommended minimal resolution 1920x1080 (width, height)

573

574 **B.4 Additional requirements per device type**

575 **B.4.1 Additional requirements for Television Devices ("oic.d.tv")**

576 A set of Resource Types have been defined that are applicable should a Device of type "oic.d.tv"
577 need to expose behaviours typically found in "settings" menus or functions. A Device should
578 expose one or more of these Resource Types:

- 579 – accessibility settings ("oic.r.settings.accessibility")
- 580 – broadcast settings ("oic.r.settings.broadcast")
- 581 – picture settings ("oic.r.settings.picture")
- 582 – sound settings ("oic.r.settings.sound")
- 583 – support settings ("oic.r.settings.support")
- 584 – general system settings ("oic.r.settings.system")
- 585 – ecomode ("oic.r.ecomode")

586 A Device may additionally expose the following Resource Types:

- 587 – software update ("oic.r.softwareupdate")
- 588 – Wi-Fi configuration ("oic.r.wificonf")

589 Thus enabling a complete set of Client accessible information typically found within a television
590 system settings user interface.

591 **Annex C**
592 (normative)

593 **Healthcare device types**
594

595 **C.1 Scope**

596 This Annex defines Device Types for use in the healthcare and fitness vertical, and describes
597 general use cases to which OCF Healthcare Devices apply, along with common functional
598 requirements.

599 Although some common requirements are defined in this document, implementation is responsible
600 for checking appropriate security, safety, environmental, and health practices, and applicable
601 regulatory requirements from national health authorities.

602 **C.2 Introduction to OCF healthcare devices**

603 This Annex references and inherits data models defined in the ISO/IEC 30118-4:2018, to define
604 OCF Healthcare Device Types in clause C.4.

605 **C.3 Operational scenarios**

606 Personal fitness and/or medical data are read by a monitoring Device (OCF Client role) from
607 Healthcare Devices (OCF Server role), and the monitoring Device triggers appropriate actions
608 based on the data collected. Many of the target usages are for personal health or fitness, although
609 clinical use cases can be realized with similar modelling.

610 As shown in Figure C.1, data from various fitness and healthcare devices can be gathered on a
611 smart phone for monitoring and can be transmitted to the healthcare services through a gateway
612 or through the smartphone. The protocol to be used for transmission is defined in ISO/IEC 30118-
613 1:2018. Collected personal fitness and/or medical data are used for condition monitoring or medical
614 research, receiving advice from a trainer/doctor, or triggering an emergency notification.

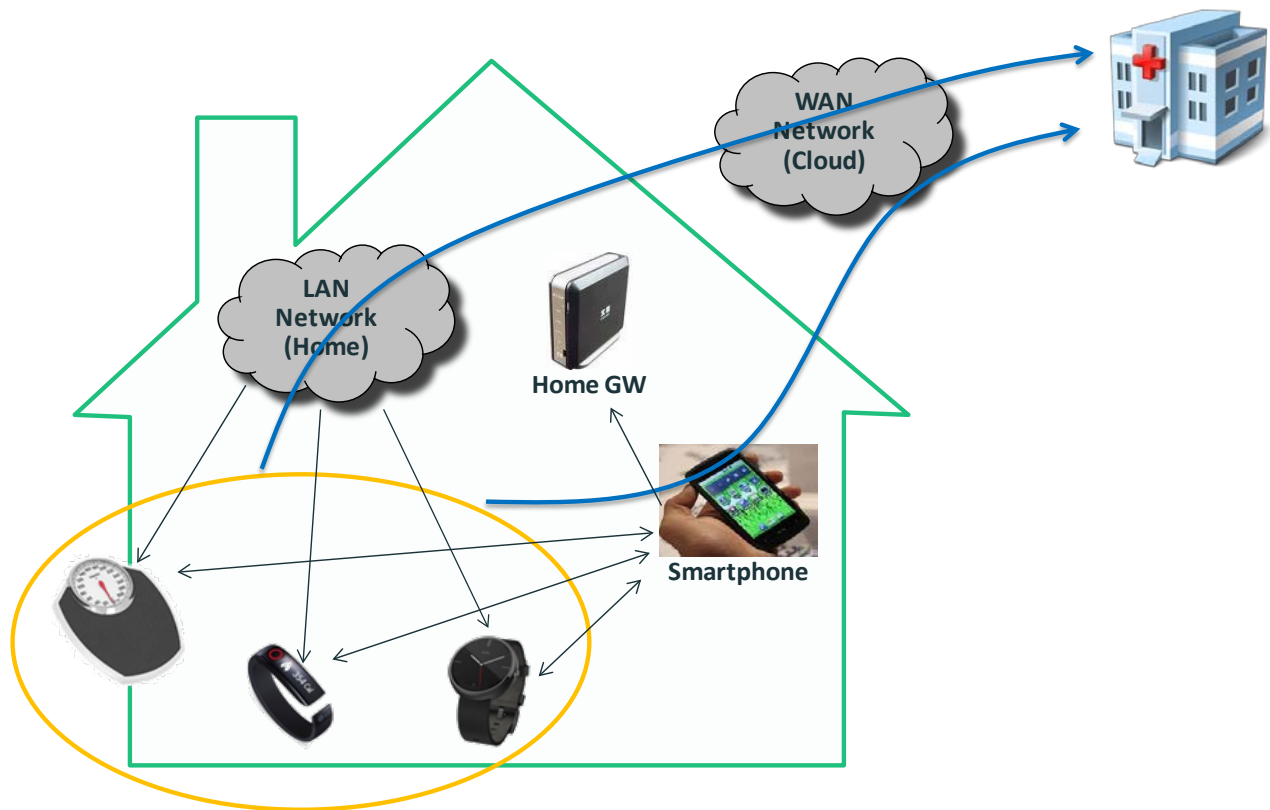

615

616

Figure C.1 – Schematic diagram of healthcare usages

617 **C.4 Standardized device types**

618 **C.4.1 Introduction**

619 OCF Healthcare Device Types specify Devices in the healthcare and fitness domains of the OCF
 620 ecosystem. The Device Type exposed by the "rt" value of /oic/d of all Healthcare Devices shall
 621 have a Resource Type value ("rt") prefixed with "oic.d." The Healthcare Device Types are listed in
 622 Table C.1.

623

Table C.1 – Alphabetical list of healthcare device types

Clause	Device Name	Device Type ("rt")
C.4.9	Activity Tracker	oic.d.activitytracker
C.4.2	Blood Pressure Monitor	oic.d.bloodpressuremonitor
C.4.15	Body Composition Analyser	oic.d.bodycompositionanalyser
C.4.4	Body Scale	oic.d.bodyscale
C.4.5	Body Thermometer	oic.d.bodythermometer
C.4.10	CGM(Continuous Glucose Monitor)	oic.d.cgm
C.4.11	Cycling Power Meter	oic.d.cyclingpowermeter
C.4.12	Cycling Speed Sensor	oic.d.cyclingspeedsensor
C.4.13	Cycling Cadence Sensor	oic.d.cyclingcadencesensor
C.4.3	Glucose Meter	oic.d.glucosemeter
C.4.6	Heart Rate Monitor	oic.d.heartratemonitor

C.4.14	Muscle Oxygen Monitor	oic.d.muscleoxygenmonitor
C.4.7	Pulse Oximeter	oic.d.pulseoximeter
C.4.8	Sleep Monitor	oic.d.sleepmonitor

624 The remainder of this Annex defines Resource Types for each Device Type, but for full definitions
625 of Resource Types, see ISO/IEC 30118-4:2018.

626 Each Device Type defines a minimal set of Resource Types that are implemented by that Device
627 Type as required Resource Types. A Healthcare Device may expose additional OCF-defined
628 optional Resource Types. It should be noted that all Resource Types are commonly available for
629 all Device Types, but if a Device Type aims to implement optional Resource Types related to
630 healthcare, it shall expose such Resource Types using the definitions provided in this annex.

631 When a Resource Type is listed as Mandatory (M) in this Annex, the Device shall:

- 632 – expose that Atomic Measurement Resource Type in /oic/res
- 633 – expose that Resource Type as a Link in the Atomic Measurement

634 The mandatory Resource Types for an Atomic Measurement shall be listed in the "rts-m" Property
635 Value.

636 When a Resource Type is listed as Optional (O) in this Annex, a Device may expose that Resource
637 Type as a Link in the Atomic Measurement, or may also expose that Resource Type as a discretely
638 discoverable Resource outside of the Atomic Measurement. For example, if a blood pressure
639 monitor (i.e. "oic.d.bloodpressuremonitor") measures pulse rate and chooses to expose that feature
640 over OCF, it exposes the "oic.r.pulserate" Resource Type as a Link in the blood pressure monitor
641 Atomic Measurement ("oic.r.bloodpressuremonitor-am"). The allowed Resource Types for an
642 instance of an Atomic Measurement (which includes both the M and O Resource Types that are
643 implemented) shall be listed in the "rts" Property Value.

644 Some Resource Types are commonly used for all Healthcare Device Types; these are provided in
645 Table C.2. Users may want to associate timestamps to the measurements when they access their
646 healthcare information (in RFC3339 date and time format, oic.r.time.stamp). A Healthcare Device
647 may be used by different users, so identifying a specific user with an ID may be appropriate
648 ("oic.r.userid"). These Resource Types are exposed as Conditionally Required Resource Types of
649 an Atomic Measurement (as defined per clause 7.8.4 of ISO/IEC 30118-1:2018) of a specific
650 Healthcare Device. The "rt" value of Resource Types that use Atomic Measurements are suffixed
651 by -am (Atomic Measurements). When present in an Atomic Measurement, "oic.r.time.stamp" and
652 "oic.r.userid" indicate the time when a sample of data is measured by a certain user.

653 **Table C.2 – Commonly used resource types of healthcare device types**

Resource Type Name	Resource Type Value	Requirement (M, S, O, CA, CR)
Observed Time	oic.r.time.stamp	O
User ID	oic.r.userid	O

654 It should also be noted that Resource-level and Property-level requirements can be different. All
655 OCF Resource Types are specified using OpenAPI 2.0 and the Properties which are defined in a
656 specific schema can either be mandatory or optional. In other words, even if a Resource Type is
657 mandatory for a Device Type, some of its Properties may not be mandatory.

658 **C.4.2 Blood pressure monitor**

659 **C.4.2.1 Introduction**

660 A blood pressure monitor measures blood pressure [i.e., systolic, diastolic, and mean arterial
661 pressure (MAP)]. Blood pressure is most frequently measured using the units of millimetres of

662 mercury (mmHg). Blood pressure is often denoted as 120/80 mmHg, which means systolic blood
 663 pressure of 120 and diastolic blood pressure of 80.

664 Table C.3 describes the Device Type for a blood pressure monitor. Table C.4 describes the Atomic
 665 Measurement that is present in all instances of a blood pressure monitor.

666 **Table C.3 – Healthcare device type of blood pressure monitor**

Device Type (rt)	Resource Type Name	Resource Type Value	Requirement level
oic.d. bloodpressuremonitor	Blood pressure monitor Atomic Measurement	oic.r.bloodpressuremonitor- am	M

667 **Table C.4 – Atomic measurement of blood pressure monitor**

Atomic Measurement Resource Type Value	Resource Type Name	Resource Type Value	Requirement level
oic.r. bloodpressuremonitor-am	Blood pressure	oic.r.blood.pressure	M
	Pulse rate	oic.r.pulserate	O

668
 669 **C.4.2.2 Required resource types**

670 A blood pressure monitor shall expose "oic.r.blood.pressure" to report the blood pressure (systolic
 671 and diastolic) and optionally MAP.

672 **C.4.2.3 OCF-defined optional resource types**

673 A blood pressure monitor measures pulse rate using the "oic.r.pulserate" Resource Type.

674 See Table C.2 for additional commonly used Resource Types that could be used here.

675 **C.4.3 Glucose meter**

676 **C.4.3.1 Introduction**

677 A glucose meter measures the concentration of glucose in the blood. Glucose, or blood sugar, is
 678 the human body's primary source of energy. The blood glucose level is a key parameter that
 679 diabetics measure multiple times per day.

680 Table C.5 describes the Device Type for a glucose meter. Table C.6 describes the Atomic
 681 Measurement that is present in all instances of a glucose meter.

682 **Table C.5 – Healthcare device type of glucose meter**

Device Type (rt)	Resource Type Name	Resource Type Value	Requirement level
oic.d.glucosemeter	Glucose meter Atomic Measurement	oic.r.glucosemeter-am	M

683 **Table C.6 – Atomic measurement of glucose meter**

Atomic Measurement Resource Type Value	Resource Type Name	Resource Type Value	Requirement level
oic.r.glucosemeter-am	Glucose	oic.r.glucose	M
	Context Carbohydrates	oic.r.glucose.carb	O
	Context Exercise	oic.r.glucose.exercise	O
	Hemoglobin Bound to Glucose A1c Form (HbA1c)	oic.r.glucose.hba1c	O

	Context Health	oic.r.glucose.health	O
	Context Meal	oic.r.glucose.meal	O
	Context Medication	oic.r.glucose.medications	O
	Context Sample Location	oic.r.glucose.samplelocation	O
	Context Tester	oic.r.glucose.testers	O

684

685 **C.4.3.2 Required resource types**

686 A glucose meter shall expose "oic.r.glucose" to report the blood glucose level in mg/dL or mmol/L.

687 **C.4.3.3 OCF-defined optional resource types**

688 A glucose meter measures context carbohydrates, then it shall expose the context carbohydrates

689 using "oic.r.glucose.carb" Resource Type.

690 A glucose meter measures context exercise using the "oic.r.glucose.exercise" Resource Type.

691 A glucose meter measures Hemoglobin Bound to Glucose A1c Form (HbA1c) using the

692 "oic.r.glucose.hba1c" Resource Type.

693 A glucose meter measures context health using the "oic.r.glucose.health" Resource Type.

694 A glucose meter measures context meal using the "oic.r.glucose.meal" Resource Type.

695 A glucose meter measures context medication using the "oic.r.glucose.medications" Resource Type.

696 A glucose meter measures context sample location using the "oic.r.glucose.samplelocation"

697 Resource Type.

698 A glucose meter measures context tester using the "oic.r.glucose.testers" Resource Type.

699 See Table C.2 for additional commonly used Resource Types that could be used here.

700 **C.4.4 Body scale**

701 **C.4.4.1 Introduction**

702 A body scale measures the weight. The weight is most frequently measured using the units of

703 kilograms (kg) or pounds (lb).

704 Table C.7 describes the Device Type for a body scale. Table C.8 describes the Atomic

705 Measurement that is present in all instances of a body scale.

706 **Table C.7 – Healthcare device type of body scale**

Device Type (rt)	Resource Type Name	Resource Type Value	Requirement level
oic.d.bodyscale	Body scale Atomic Measurement	oic.r.bodyscale-am	M

707

708 **Table C.8 – Atomic measurement type of body scale**

Atomic Measurement Resource Type Value	Resource Type Name	Resource Type Value	Requirement level
oic.r.bodyscale-am	Weight	oic.r.weight	M
	Body Mass Index (BMI)	oic.r.bmi	O

	Height	oic.r.height	O
	Body Fat	oic.r.body.fat	O
	Body Water	oic.r.body.water	O
	Body Soft Lean Mass	oic.r.body.slm	O
	Body Fat Free Mass	oic.r.body.ffmpeg	O

709 **C.4.4.2 Required resource types**

710 A body scale shall expose "oic.r.weight" to report the body weight of a person.

711 **C.4.4.3 OCF-defined optional resource types**

712 A body scale measures height using the "oic.r.height" Resource Type. Especially, a body scale
713 measures the height if BMI is also reported because the height is used when a body scale measures
714 BMI.

715 A body scale measures Body Mass Index (BMI) using the "oic.r.bmi" Resource Type.

716 A body scale measures body fat using the "oic.r.body.fat" Resource Type.

717 A body scale measures body water using the "oic.r.body.water" Resource Type.

718 A body scale measures body soft lean mass using the "oic.r.body.slm" Resource Type.

719 A body scale measures body fat free mass using the "oic.r.body.ffmpeg" Resource Type.

720 See Table C.2 for additional commonly used Resource Types that could be used here.

721 **C.4.5 Body thermometer**

722 **C.4.5.1 Introduction**

723 A body thermometer measures the temperature at some point. In general, the body thermometer
724 is placed at the measurement site for sufficient time for the measuring probe to reach the same
725 temperature as the body site, and when stable, a direct digital reading of the probe temperature is
726 taken.

727 Table C.9 describes the Device Type for a body thermometer. Table C.10 describes the Atomic
728 Measurement that is present in all instances of a body thermometer.

729 **Table C.9 – Healthcare device type of body thermometer**

Device Type (rt)	Resource Type Name	Resource Type Value	Requirement level
oic.d.bodythermometer	Body thermometer Atomic Measurement	oic.r.bodythermometer-am	M

730 **Table C.10 – Atomic measurement type of body thermometer**

Atomic Measurement Resource Type Value	Resource Type Name	Resource Type Value	Requirement level
oic.r.bodythermometer-am	Temperature	oic.r.temperature	M
	Body Location for temperature	oic.r.body.location.temperature	O

731 **C.4.5.2 Required resource types**

732 A body thermometer shall expose "oic.r.body.temperature" to report the temperature level and the
733 unit of a measured temperature is reported either in C, F or K.

734 **C.4.5.3 OCF-defined optional resource types**

735 A body thermometer measures temperature site using the "oic.r.body.location.temperature"
736 Resource Type.

737 See Table C.2 for additional commonly used Resource Types that could be used here.

738 **C.4.6 Heart rate monitor**

739 **C.4.6.1 Introduction**

740 A heart rate monitor measures heart rate. Heart rate is most frequently measured using the units
741 of beats per minute (bpm). While normal heart rate varies from person to person depending on the
742 individual, age, body size, heart conditions, posture, medication use, etc., normal resting heart rate
743 range for adults is from 60 to 100 according to the American Heart Association.

744 Table C.11 describes the Device Type for a heart rate monitor. Table C.12 describes the Atomic
745 Measurement that is present in all instances of a heart rate monitor.

746 **Table C.11 – Healthcare device type of heart rate monitor**

Device Type (rt)	Resource Type Name	Resource Type Value	Requirement level
oic.d.heartratemonitor	Heart Rate Monitor Atomic Measurement	oic.r.heartratemonitor -am	M

747 **Table C.12 – Atomic measurement of heart rate monitor**

Atomic Measurement Resource Type Value	Resource Type Name	Resource Type Value	Requirement level
oic.r.heartratemonitor -am	Heart Rate	oic.r.heartrate	M

748 **C.4.6.2 Required Resource Types**

749 A heart rate monitor shall expose "oic.r.heartrate" to report the heart rate of a person.

750 **C.4.6.3 OCF-defined Optional Resource Types**

751 See Table C.2 for additional commonly used Resource Types that could be used here.

752 **C.4.7 Pulse oximeter**

753 **C.4.7.1 Introduction**

754 A pulse oximeter measures peripheral capillary oxygen saturation (SpO2), an estimate of the
755 amount of oxygen in the blood. Oxygen saturation is most frequently measured using percentage
756 (%). Normal oxygen saturation is 95% or above according to the World Health Organization (WHO).

757 Table C.13 describes the Device Type for a pulse oximeter. Table C.14 describes the Atomic
758 Measurement that is present in all instances of a pulse oximeter.

759 **Table C.13 – Healthcare device type of pulse oximeter**

Device Type (rt)	Resource Type Name	Resource Type Value	Requirement level
oic.d.pulseoximeter	Pulse Oximeter Atomic Measurement	oic.r.pulseoximeter-am	M

760

Table C.14 – Atomic measurement of pulse oximeter

Atomic Measurement Resource Type Value	Resource Type Name	Resource Type Value	Requirement level
oic.r.pulseoximeter-am	SpO2	oic.r.spo2	M
	Pulse Rate	oic.r.pulserate	M
	Pulsatile Occurrence	oic.r.pulsatileoccurrence	O
	Pulsatile Characteristic	oic.r.pulsatilecharacteristic	O

761 **C.4.7.2 Required Resource Types**

762 A pulse oximeter shall expose "oic.r.spo2" to report the oxygen saturation of a person.

763 A pulse oximeter shall expose "oic.r.pulserate" to report the pulse rate of a person.

764

765 **C.4.7.3 OCF-defined Optional Resource Types**766 A pulse oximeter measures pulsatile occurrence using the "oic.r.pulsatileoccurrence" Resource
767 Type.768 A pulse oximeter measures pulsatile characteristic using the "oic.r.pulsatilecharacteristic"
769 Resource Type.

770 See Table C.2 for additional commonly used Resource Types that could be used here.

771 **C.4.8 Sleep monitor**772 **C.4.8.1 Introduction**773 A sleep monitor measures the duration of each one of the sleep stages, and can also compute a
774 "Sleep Score" from these data. The stages of sleep are: NREM stage 1 (Light Sleep stage 1),
775 NREM stage 2 (Light Sleep stage 2), NREM stage 3 (Deep Sleep stage 1), NREM stage 4 (Deep
776 Sleep stage 2), REM.777 A night of sleep is composed of several sleep cycles, with each sleep cycle progressing from
778 Light Sleep to Deep Sleep, before reversing back from Deep Sleep to Light Sleep, ending with
779 REM.780 The first cycle takes about 90 minutes. After that, the cycles average between 100 minutes and
781 120 minutes. Typically, an individual will go through 4 to 5 sleep cycles per night. Dreams occur
782 during REM stages.783 NREM stage 4 is not recognized in every country: in 2007, the USA merged NREM stages 3 and
784 4 into only one stage, NREM stage 3, thus effectively removing NREM stage 4.

785 Light Sleep consists of NREM stages 1 and 2. Deep Sleep consists of NREM stages 3 and 4.

786 Table C.15 describes the Device Type for a sleep monitor. Table C.16 describes the Atomic
787 Measurement that is present in all instances of a sleep monitor.

788

Table C.15 – Healthcare device type of sleep monitor

Device Type (rt)	Resource Type Name	Resource Type Value	Requirement level
oic.d.sleepmonitor	Sleep Monitor Atomic Measurement	oic.r.sleepmonitor-am	M

789

790

Table C.16 – Atomic measurement of sleep monitor

Atomic Measurement Resource Type Value	Resource Type Name	Resource Type Value	Requirement level
oic.r.sleepmonitor-am	Sleep	oic.r.sleep	M
	Heart Rate	oic.r.heartrate	O

791 **C.4.8.2 Required Resource Types**

792 A sleep monitor shall expose "oic.r.sleep" to report the time spent in the Awake, NREM1,
793 NREM2, NREM3 and REM stages, and optionally the time spent in the NREM4, Light Sleep,
794 Deep Sleep stages, and the sleep score.

795 **C.4.8.3 OCF-defined Optional Resource Types**

796 A sleep monitor measures the heartrate using the "oic.r.heartrate" Resource Type.

797 See Table C.2 for additional commonly used Resource Types that could be used here.

798 **C.4.9 Activity tracker**799 **C.4.9.1 Introduction**

800 An Activity Tracker measures a user's activities. An Activity Tracker shows a user's current activity
801 type, accumulated step counts per day since the beginning of the day (or last reset), consumed
802 calories per day since the beginning of the day (or last reset), and alarm status.

803 Table C.17 describes the Device Type for an activity tracker. Table C.18 describes the Atomic
804 Measurement that is present in all instances of an activity tracker.

805 **Table C.17 – Healthcare device type of activity tracker**

Device Type (rt)	Resource Type Name	Resource Type Value	Requirement level
oic.d.activitytracker	Activity Tracker Atomic Measurement	oic.r.activitytracker-am	M
	Clock	oic.r.clock	O
	Battery	oic.r.energy.battery	O
	Alarm	oic.r.alarm	O

806

807 **Table C.18 – Atomic measurement of activity tracker**

Atomic Measurement Resource Type Value	Resource Type Name	Resource Type Value	Requirement level
oic.r.activitytracker-am	Activity	oic.r.activity	M
	Heartrate	oic.r.heartrate	O

808 **C.4.9.2 Required Resource Types**

809 An activity tracker shall expose "oic.r.activity" to report the activity of a person, and optionally the
810 number of steps per day or since last reset, plus the consumed calories per day or since last reset.

811 **C.4.9.3 OCF-defined Optional Resource Types**

812 An activity tracker manages the alarm status using the "oic.r.alarm" Resource Type.

813 An activity tracker measures heart rate using the "oic.r.heartrate" Resource Type.

814 An activity tracker measures time using the "oic.r.clock" Resource Type.

815 An activity tracker measures battery status using the "oic.r.energy.battery" Resource Type.

816 See Table C.2 for additional commonly used Resource Types that could be used here.

817 **C.4.10 CGM (Continuous Glucose Meter)**

818 **C.4.10.1 Introduction**

819 A CGM is a device that measures the concentration of glucose in the blood, typically measured
 820 from interstitial fluid (ISF). The glucose concentration is available on a continual basis at a periodic
 821 interval from a sensor. Glucose, or blood sugar, is the human body's primary source of energy.
 822 Frequent measurements provided by a CGM give a patient greater insight as to the fluctuations in
 823 blood glucose levels throughout the day, and in turn, can reduce the risk of developing diabetic
 824 complications.

825 Table C.19 describes the Device Type for a CGM. Table C.20 describes the Atomic Measurement
 826 that is present in all instances of a CGM.

827 **Table C.19 – Healthcare device type of CGM**

Device Type (rt)	Resource Type Name	Resource Type Value	Requirement level
oic.d.cgm	CGM Atomic Measurement	oic.r.cgm-am	M
	CGM Sampling Interval	oic.r.cgm.samplinginterval	M
	CGM Calibration	oic.r.cgm.calibrate	M
	CGM Threshold	oic.r.cgm.threshold	M
	CGM Status	oic.r.cgm.status	O
	Battery	oic.r.energy.battery	O

828

829 **Table C.20 – Atomic measurement of CGM**

Atomic Measurement Resource Type Value	Resource Type Name	Resource Type Value	Requirement level
oic.r.cgm-am	Glucose	oic.r.glucose	M
	CGM Sensor	oic.r.cgm.sensor	O

830 **C.4.10.2 Required Resource Types**

831 A CGM shall expose "oic.r.glucose" to report the blood glucose level in mg/dL or mmol/L.

832 A CGM shall manage (RETRIEVE and UPDATE) the CGM Sampling Interval using the
 833 "oic.r.cgm.samplinginterval" Resource Type.

834 A CGM shall manage (RETRIEVE and UPDATE) CGM Calibration using the "oic.r.cgm.calibrate"
 835 Resource Type.

836 A CGM shall manage (RETRIEVE and UPDATE) CGM Threshold using the "oic.r.cgm.threshold"
 837 Resource Type.

838 **C.4.10.3 OCF-defined Optional Resource Types**

839 A CGM measures CGM sensor information using the "oic.r.cgm.sensor" Resource Type.

840 A CGM measures CGM Status using the "oic.r.cgm.status" Resource Type.

841 A CGM measures Battery using the "oic.r.energy.battery" Resource Type.

842 See Table C.2 for additional commonly used Resource Types that could be used here.

843 **C.4.11 Cycling power meter**

844 **C.4.11.1 Introduction**

845 A cycling power meter is a sensor that is mounted on a bicycle and that allows the cyclist to
846 measure his or her power output, which is used to move the bike forward and is measured in Watts.
847 The meter transmits the information to OCF Clients. A cycling power meter uses different
848 measurements to determine power:

- 849 – measure power directly
- 850 – measure torque and rotational velocity at the crank
- 851 – measure torque and rotational velocity at the wheel

852 Possible methods used by a cycling power meter for information updates include:

- 853 – Event-Synchronous Update e.g. the power information is updated each time the power sensor
854 detects a new crank rotation.
- 855 – Time-Synchronous Update e.g. the power information is updated at 1Hz.

856 Table C.21 describes the Device Type for a cycling power meter.

857 **Table C.21 – Healthcare device type of cycling power meter**

Device Type (rt)	Resource Type Name	Resource Type Value	Requirement level
oic.d.cyclingpowermeter	Cycling power	oic.r.cyclingpower	M
	Torque	oic.r.torque	O
	Cadence	oic.r.cadence	O

858 **C.4.11.2 Required Resource Types**

859 A cycling power meter shall expose "oic.r.cyclingpower" to report the measured power output (which
860 is the power used to move the bike forward).

861 **C.4.11.3 OCF-defined Optional Resource Types**

862 A cycling power meter measures the torque at the crank or the wheel using the "oic.r.torque"
863 Resource Type.

864 A cycling power meter measures the cadence, which is the number of revolutions of crank per
865 minute when cyclists pedal the pedals, at the crank or the wheel using the "oic.r.cadence"
866 Resource Type.

867 See Table C.2 for additional commonly used Resource Types that could be used here.

868 **C.4.12 Cycling speed sensor**

869 **C.4.12.1 Introduction**

870 Cycling speed sensors are devices mounted on a bicycle that measure the speed the bicycle is
871 travelling. This is typically done using a magnet mounted on the wheel spokes and a sensor on the
872 bicycle frame that senses the magnet passing.

873 Table C.22 describes the Device Type for a cycling speed sensor.

874 Note: The notion 'Sensor' of the Device Name (Cycling Speed Sensor) is not associated with 'sensor', which is an OCF
875 standard OCF Interfaces defined in ISO/IEC 30118-1:2018.

876

Table C.22 – Healthcare device type of cycling speed sensor

Device Type (rt)	Resource Type Name	Resource Type Value	Requirement level
oic.d.cyclingspeedsensor	Speed	oic.r.speed	M

877

878 C.4.12.2 Required Resource Types

879 A cycling speed sensor shall expose "oic.r.speed" to report the speed the bicycle is travelling.

880 C.4.12.3 OCF-defined Optional Resource Types

881 See Table C.2 for additional commonly used Resource Types that could be used here

882 C.4.13 Cycling cadence sensor**883 C.4.13.1 Introduction**

884 Cycling cadence sensors measure the speed at which the user is pedaling, typically using a magnet
885 attached to the pedal shaft and a sensor mounted on the frame.

886 Table C.23 describes the Device Type for a cycling speed sensor.

887 Note: The notion 'Sensor' of the Device Name (Cycling Cadence Sensor) is not associated with 'sensor', which is an OCF
888 standard OCF Interfaces defined in ISO/IEC 30118-1:2018.

889

Table C.23 – Healthcare device type of cycling cadence sensor

Device Type (rt)	Resource Type Name	Resource Type Value	Requirement level
oic.d.cyclingcadencesensor	Cadence	oic.r.cadence	M

890

891 C.4.13.2 Required Resource Types

892 A cycling cadence sensor shall expose "oic.r.cadence" to report the cadence, which is the
893 number of revolutions of crank per minute when cyclists pedal the pedals.

894 C.4.13.3 OCF-defined Optional Resource Types

895 See Table C.2 for additional commonly used Resource Types that could be used here

896 C.4.14 Muscle oxygen monitor**897 C.4.14.1 Introduction**

898 A muscle oxygen monitor provides an indication of the muscle oxygen saturation (SmO₂) and is used by
899 athletes to monitor the intensity of their training, and by coaches and physiotherapists to identify which
900 and when muscles are being used.

901 SmO₂ is a measure of the percentage of hemoglobin that is saturated with oxygen in the capillaries of a
902 muscle. SmO₂ decreases as a muscle does work, for example, when a person is exercising. SmO₂
903 increases when blood circulation brings new oxygen to the muscle. SmO₂ varies from muscle to muscle
904 depending on which muscle is used to perform a particular action.

905 Table C.24 describes the Device Type for a muscle oxygen monitor.

906

Table C.24 – Healthcare Device Type of muscle oxygen monitor

Device Type (rt)	Resource Type Name	Resource Type Value	Requirement level
oic.d.muscleoxygenmonitor	Muscle Oxygen Saturation	oic.r.muscleoxygensaturation	M

907

908 **C.4.14.2 Required Resource Types**

909 A muscle oxygen monitor shall expose "oic.r.muscleoxygensaturation" to report the muscle
910 oxygen saturation (SmO2).

911 **C.4.14.3 OCF-defined Optional Resource Types**

912 See Table C.2 for additional commonly used Resource Types that could be used here.

913 **C.4.15 Body composition analyser**

914 **C.4.15.1 Introduction**

915 A body composition analyser is a device that analyzes the composition of a human body including body
916 fat, body height, body weight, etc. A body composition analyser uses various techniques for measuring
917 the composition of a human body. For example, body impedance analysis measures the bioelectrical
918 impedance with electrical signals sent from pairs of probes (typically metal electrodes) applied at the feet
919 and/or hands and evaluates the body composition from these impedances.

920 Table C.25 describes the Device Type for a body composition analyser. Table C.26 describes the
921 Atomic Measurement that is present in all instances of a body composition analyser.

922 **Table C.25 – Healthcare device type of body composition analyser**

Device Type (rt)	Resource Type Name	Resource Type Value	Requirement level
oic.d.bodycompositionanalyser	Body composition analyser Atomic Measurement	oic.r.bodycompositionanalyser-am	M

923

924 **Table C.26 – Atomic measurement type of body composition analyser**

Device Type (rt)	Resource Type Name	Resource Type Value	Requirement level
oic.r.bodycompositionanalyser-am	Body fat	oic.r.body.fat	M
	Height	oic.r.height	M
	Weight	oic.r.weight	M
	Body Fat Free Mass	oic.r.body.ffm	O
	Body Soft Lean Mass	oic.r.body.slm	O
	Body Water	oic.r.body.water	O
	Body Mass Index (BMI)	oic.r.bmi	O

925

926 **C.4.15.2 Required Resource Types**

927 A body composition analyser shall expose "oic.r.body.fat" to report the body fat of a person.

928 A body composition analyser shall expose "oic.r.height" to report the height of a person.

929 A body composition analyser shall expose "oic.r.weight" to report the weight of a person.

930

931 **C.4.15.3 OCF-defined Optional Resource Types**

932 A body composition analyser measures body fat free mass using the "oic.r.body.ffm" Resource
933 Type.

934 A body composition analyser measures body soft lean free mass using the "oic.r.body.slm"
935 Resource Type.

- 936 A body composition analyser measures body water using the "oic.r.body.water" Resource Type.
- 937 A body composition analyser measures Body Mass Index (BMI) using the "oic.r.bmi" Resource
938 Type.
- 939 See Table C.2 for additional commonly used Resource Types that could be used here.

940 **Annex D**
941 **(normative)**

942 **Industrial device types**
943

944 **D.1 Operational scenarios**

945 The Optical RFID Tag and Optical RFID Station Resource Types describe the attributes associated
946 with an optical augmented RFID system of a smart factory environment for integrating the
947 observation and the actuation in production lines of plants.

948 Commercial observation is the real-time monitoring to collect broad series of data from each
949 product on the production line and machineries from the plant floor. This collected big data can be
950 sent to OCF cloud and/or manufacturer's internal OCF network where it is analysed and used to
951 estimate overall production flow, productivity and identify failure parts.

952 Commercial actuation is the real-time interaction to take actions on system failures such as
953 defected product's isolation, possibly sending the product into a repair line, alarming, such as
954 production line status, display panels and hazard issues such as fire and flood of the Commercial
955 environment by sending actuation requests to actuators directly and/or to client(s).

956 Optical augmented RFID reader and tag assist in production line control utilizing the OCF
957 ecosystem for smart factory environment. The optical augmented RFID reader is represented by
958 the RFID Station Resource Type, the tag by the RFID Tag Resource Type.

959 In the RFID Tag Resource Type, the tagid is an integer showing the currently read optical
960 augmented RFID tag's identity information.

961 In the RFID Station Resource Type, the process represents the stage of the product in the product
962 line which has an optical RFID tag on its body. Event is represented by a Boolean value set to
963 "True" or "False" alarming the issue when additional action is requested for the tagged product.
964 actionrequest represents necessary actions like the isolation of the product, to send the product
965 back to another specific line to modify or fix an issue.

966 Figure D.1 shows a normal, non-error case process flow in the smart factory. Blue arrow lines are
967 where OCF communication exists. ORFID tag ID is only readable to maintain consistent identity.

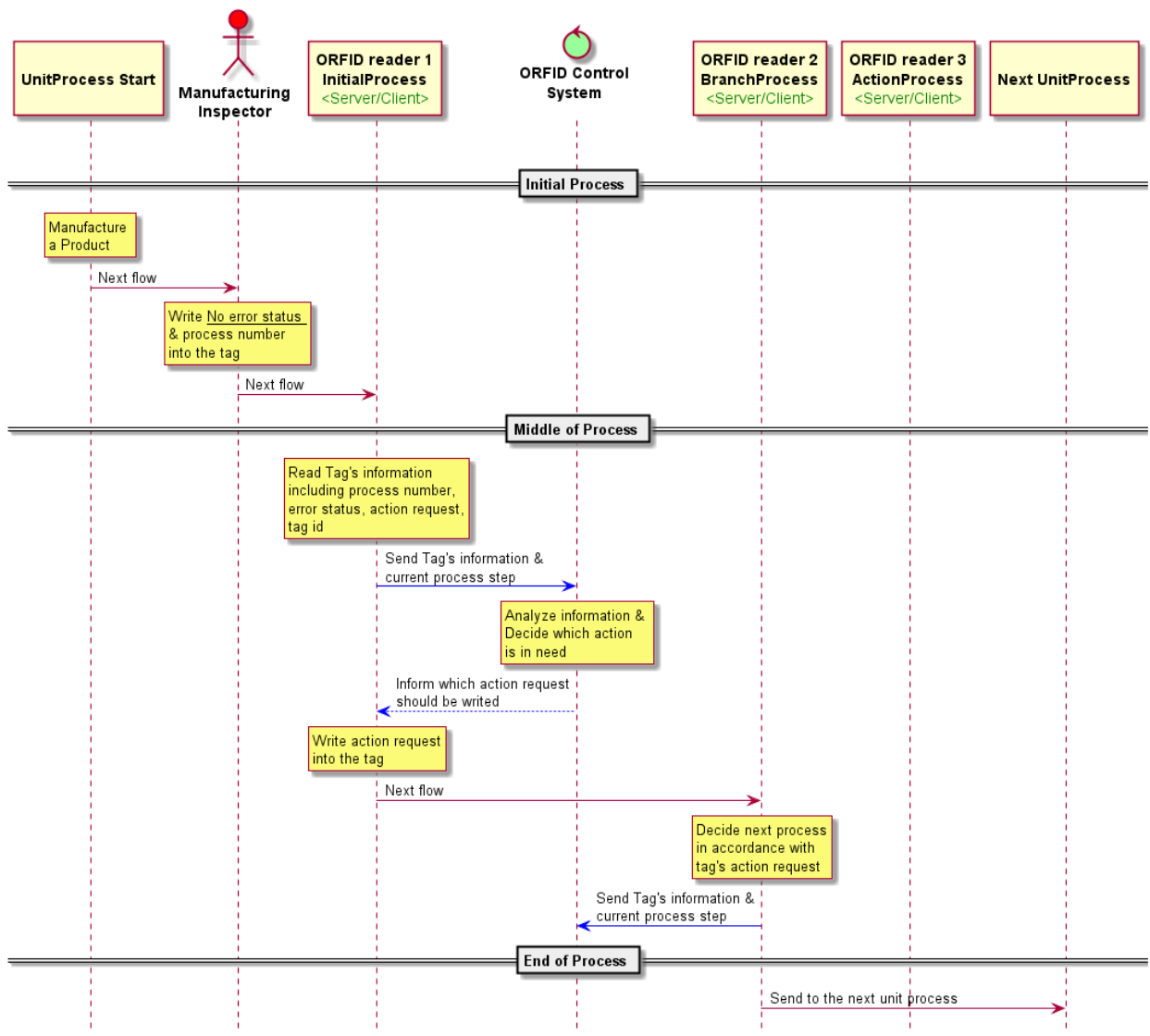

968

969

970

Figure D.1 – Normal process scheme of optical augmented RFID in smart factory environment

971

972

Figure D.2 shows product error control scheme in the smart factory. Blue arrow lines are where OCF communication exists. ORFID tag ID is only readable to maintain consistent identity.

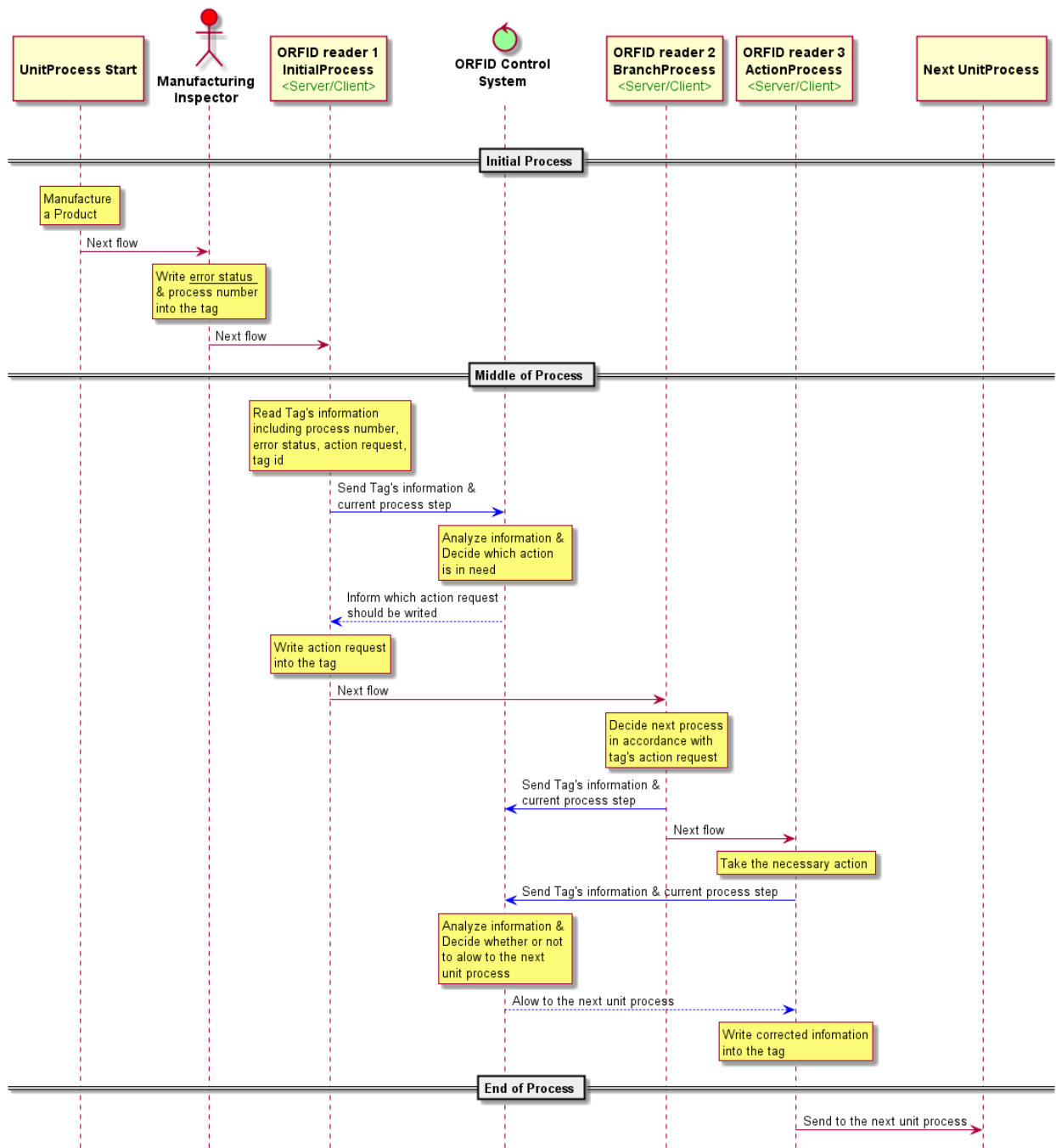

973

974

975

Figure D.2 – Abnormal process scheme of optical augmented RFID in smart factory environment

976 Manufacturing Inspector writes "error status" and "process number" into the tag after manufacturing
 977 a product. ORFID reader1 reads Tag's information and sends the information including current
 978 process step to ORFID Control System. Then ORFID reader1 waits until ORFID Control System
 979 replies. When ORFID reader1 receives "action request" from ORFID Control System. ORFID
 980 reader1 writes "action request" into the tag.

981 ORFID reader2 located at the "BranchProcess" line decides next flow in accordance with tag's
 982 "action request" information then it sends Tag's information and current process step to ORFID
 983 Control System, and sends the product to the right flow.

984 If the product has an error, the product gets necessary action at "ActionProcess" line. Then ORFID
 985 reader3 sends repaired product's information. Then ORFID reader3 waits until ORFID Control
 986 System replies. When ORFID reader3 receives instruction from ORFID Control System for the next
 987 flow, ORFID reader3 sends the product according to instruction.

988 **D.2 Industrial required resources per device type**

989 Device Types may mandate that specific Resources be implemented. The required Resource per
 990 Device Type where mandated by the Industrial vertical is listed in Table B.1.

991 **Table D.1 – Alphabetical list of device types ("rt"), including required resources for**
 992 **Industrial**

Device Name (informative)	Device Type ("rt") (Normative)	Required Resource name	Required Resource Type
Optical augmented RFID Reader	oic.d.orfid	Optical RFID Tag	oic.r.orfid.tag
		Optical RFID Station	oic.r.orfid.station

993

994 **Annex E**
995 **(normative)**

996
997 **PV (Photovoltaic) system device types**

998 **E.1 Scope**

999 This Annex defines Device Types for use in PV (Photovoltaic) systems and describes general use
1000 cases to which OCF PV system Devices apply, along with common functional requirements. This
1001 Annex considers one of the typical PV system configurations, which is composed of one or more
1002 PV array systems, battery systems, inverters, and circuit breakers.

1003 **E.2 Operational scenarios**

1004 An electrical grid facility can be classified into utility side and customer sides. The utility side facility
1005 includes electricity generation, transmission, and distribution. The customer side facility includes
1006 high and low voltage equipment, distributed renewable energy equipment, and so on. Figure E.1
1007 shows the overall classification of an electrical grid facility. The utility side facility is generally
1008 managed by using IEC 61850 (Communication networks and systems for power utility automation)
1009 series standards. Especially, IEC 61850-7-1:2011 defines the data models for electrical equipment
1010 for the utility side. OCF defines the data models for devices in the residential environment, so
1011 electrical equipment in the customer side of the electrical grid facility also needs to be defined.
1012 Since electrical equipment in the utility side uses data models defined in IEC 61850 standards,
1013 customer side equipment also needs to be defined with consideration to IEC 61850 data models.

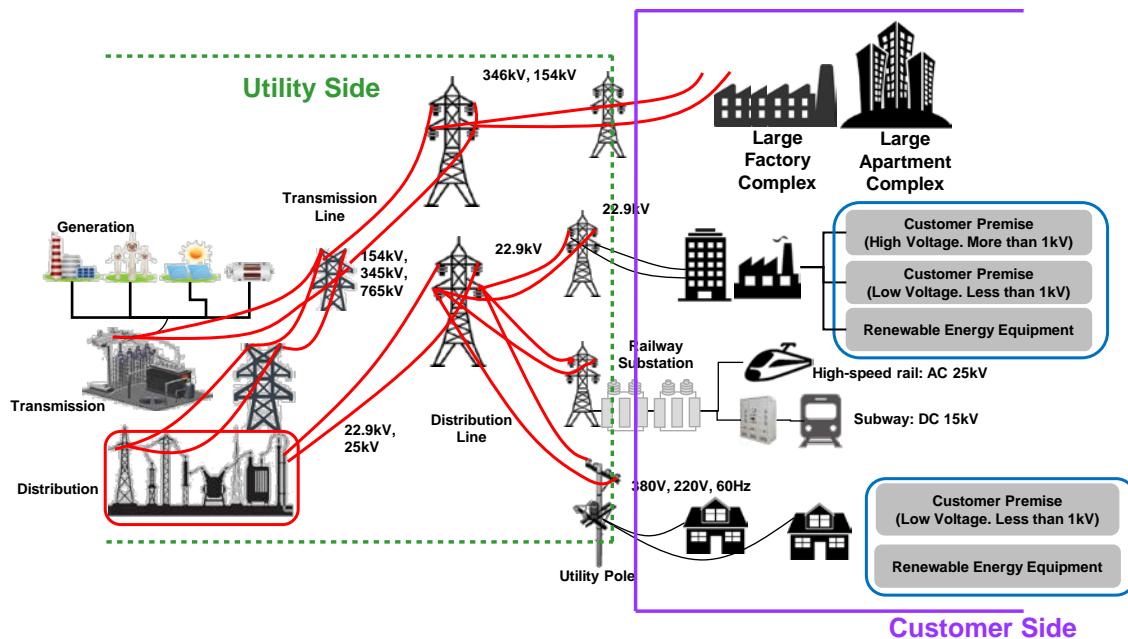

1014
1015 **Figure E.1 – Classification of electrical grid facility**

1016 Figure E.2 depicts a typical PV system configuration. As shown in the figure, a PV system consists of
1017 one or more PV array systems, DC (Direct Current)/AC (Alternating Current) inverters, battery
1018 systems, and circuit breakers. A PV array system converts the sun's rays into electricity and the
1019 generated DC current is converted into AC current by a DC/AC inverter. A battery system may be
1020 used to store generated electricity and discharge it to the electrical grid later. A circuit breaker is

1021 installed in order to disconnect the circuit between the PV system and the internal distribution grid.
1022 In this use case, the PV array system, battery system, DC/AC inverter, and circuit breaker are
1023 considered.

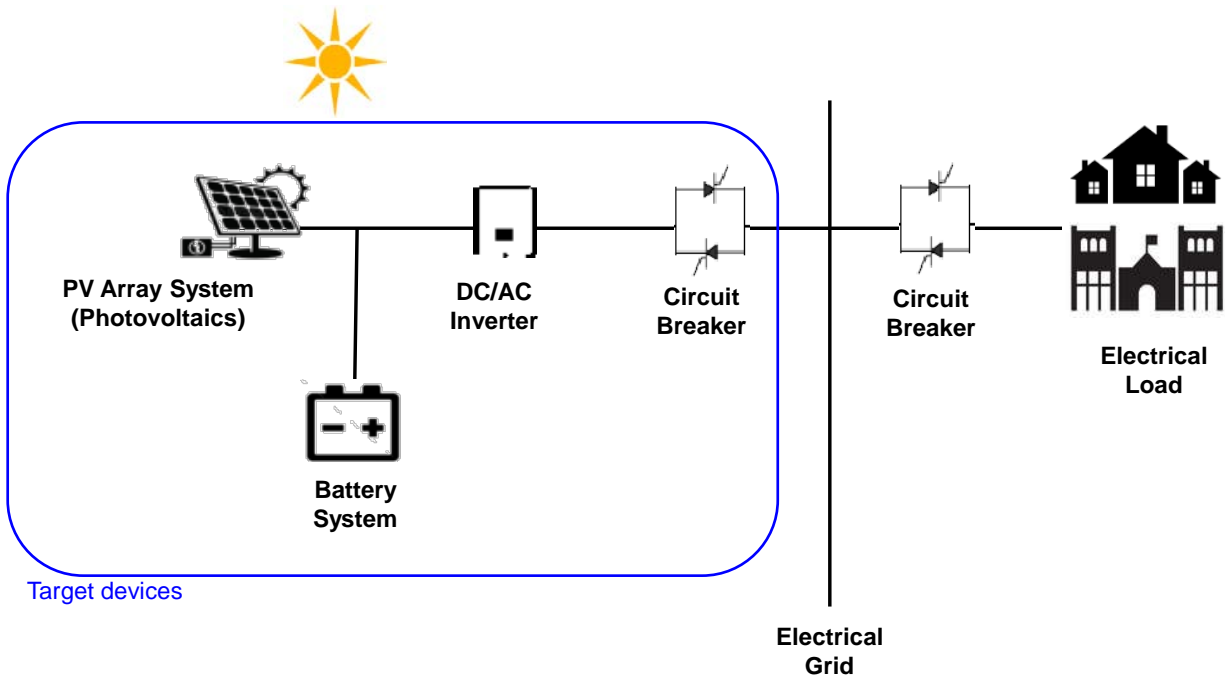

1024

1025

Figure E.2 – Typical PV system configuration

1026 Figure E.3 shows the detailed configuration of the PV array system. The PV panel is composed of
1027 a durable glass panel (array) and a rigid frame made up of durable units (modules) after the unit
1028 cells are integrated and electrically connected. The PV array is connected through the connection
1029 terminal and the connection terminal monitors the status of each PV array. The connection terminal
1030 passes through the inverter before passing AC current to the electrical grid.

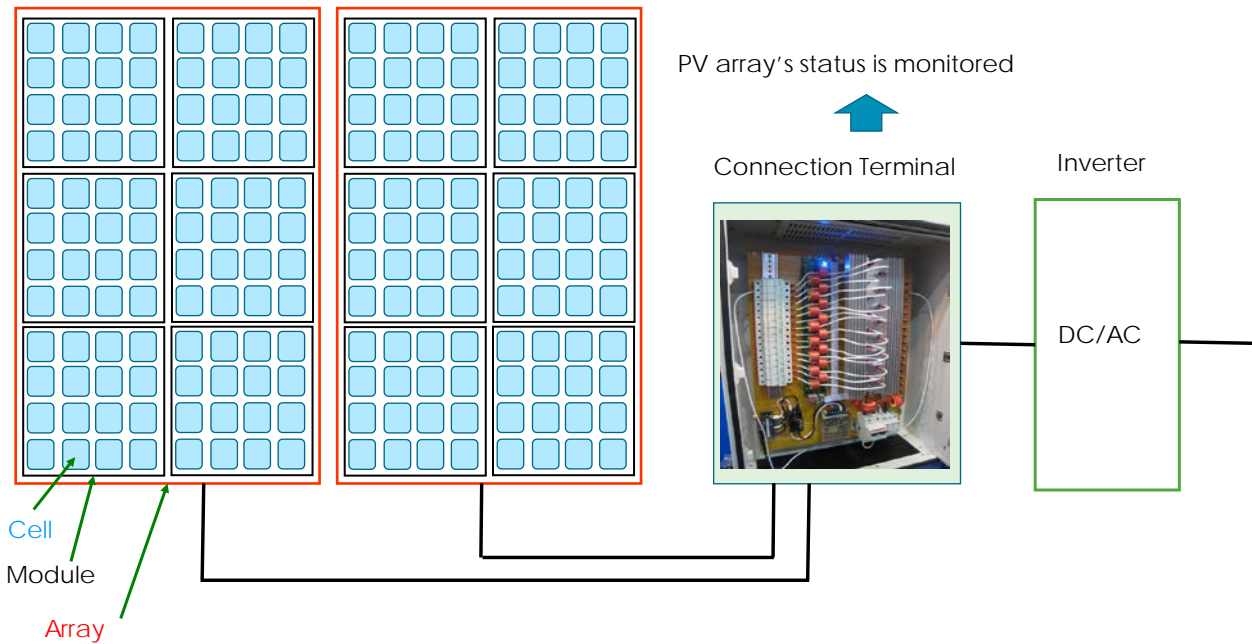

1031

1032

Figure E.3 – Detailed configuration of PV array system

1033

E.3 Standard device types

1034

Table E.1 lists the brief explanation of the function and required resources of PV system Devices.

1035

Table E.2 lists PV system Device Types. The Device Type exposed by the "rt" value of /oic/d of all

1036

PV system Devices shall have a Resource Type value ("rt") prefixed with "oic.d.".

1037

Table E.1 – Function and required resources for PV system device types

Device Name	Roles of Device	Required Resource and Function
Circuit Breaker	Functions for the control and monitoring of circuit breakers	Circuit breaker: describes circuit breakers used in the protection of the PV system
Battery System	Functions required to store excess energy produced by the PV system. Energy storage in PV systems is usually done with batteries	Battery: battery if needed for energy storage
Inverter	Functions for the control and monitoring of the DC/AC inverter	Inverter: converts DC to AC
PV Array System	Functions to maximize the power output of the PV array	PV Connection Terminal: PV array(s) is connected and status is monitored

1038

1039

Table E.2 – List of PV system device types

Device Name	Device Type (rt)	Required Resource Name	Required Resource Type
Circuit Breaker	oic.d.circuitbreaker	circuit breaker	oic.r.circuitbreaker
Battery System	oic.d.battery	battery	oic.r.energy.battery
Inverter	oic.d.inverter	inverter	oic.r.inverter

PV Array System	oic.d.pvarraysystem	PV connection terminal	oic.r.pvconnectionterminal
-----------------	---------------------	------------------------	----------------------------